

# Trunnion Ball Valves



## 83 Series and H83 Series

- Working pressures up to 10 000 psig (689 bar)
- 1/8 to 1/2 in. and 6 to 12 mm Swagelok® tube fitting or NPT end connections
- 316 stainless steel materials

## Contents

Features . . . . .	2	Materials of Construction . . . . .	4
Important Information About Ball Valves . . . . .	2	Ordering Information and Dimensions . . . . .	6
Technical Data . . . . .	2	Options and Accessories . . . . .	8
Pressure-Temperature Ratings . . . . .	3	Service Options . . . . .	9
Flow Data at 70°F (20°C) . . . . .	3	Pneumatic Actuators . . . . .	11
Testing . . . . .	3	ISO 5211-Compliant Actuators . . . . .	14
Low Fugitive Emissions . . . . .	3	Electric Actuators . . . . .	16
Cleaning and Packaging . . . . .	3		

## Features

- Compact, maximum-flow design
- Low operating torque
- 2- or 3-way flow patterns
- Panel mounting
- Pneumatic and electric actuators available
- Low Emissions certification per API 641 available

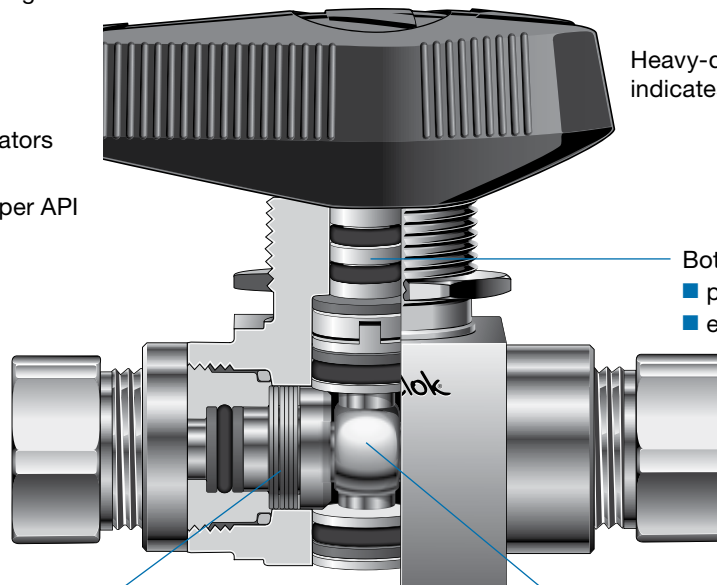

Heavy-duty handle indicates flow direction.

Bottom-loaded stem:

- prevents stem blowout
- enhances system safety.

Spring-loaded seats:

- provide leak-tight integrity in both low- and high-pressure systems
- contribute to low operating torque
- reduce seat wear from pressure surges.

Trunnion-style ball:

- prevents ball blowout
- contributes to low operating torque.

## Important Information About Ball Valves

- ⚠ Swagelok ball valves are designed to be used in a fully open or fully closed position.
- ⚠ Valves that have not been cycled for a period of time may have a higher initial actuation torque.

## Technical Data

Seat Material	Temperature Rating °F (°C)	Pressure Rating at 100°F (37°C) psig (bar)		Flow Coefficient (C <sub>v</sub> )
		Stainless Steel	Alloy 400	
<b>83 Series</b>				
PCTFE, reinforced nylon	0 to 250 (-17 to 121)	6000 (413)	5000 (344)	2-way valves— 1.0 to 1.6 depending on end connection; 3-way valves— 0.75
PEEK	0 to 450 (-17 to 232)	6000 (413)	5000 (344)	
PTFE		1500 (103)		
<b>H83 Series</b>				
PEEK	0 to 450 (-17 to 232)	6000 to 10 000 (413 to 689) depending on end connection	—	2-way valves— 1.0 to 1.6 depending on end connection; 3-way valves— 0.75

## Pressure-Temperature Ratings

### 83 Series

Pressure-temperature ratings for 83 series valves are based on listed seat materials, fluorocarbon FKM O-rings, and reinforced PTFE backup rings.

Low-temperature L83 series ball valves are available, see page 9.

Material	316 SS			Alloy 400		
	Seat Material	PCTFE, Nylon	PTFE	PEEK	PCTFE, Nylon	PTFE
Temperature, °F (°C)	Working Pressure, psig (bar)					
0 (-17) to 100 (37)	6000 (413)	1500 (103)	6000 (413)	5000 (344)	1500 (103)	5000 (344)
150 (65)	3000 (206)	1125 (77.5)	5800 (399)	3000 (206)	1125 (77.5)	4690 (323)
200 (93)	2000 (137)	750 (51.6)	5000 (344)	2000 (137)	750 (51.6)	4390 (302)
250 (121)	1000 (68.9)	625 (43.0)	4100 (282)	1000 (68.9)	625 (43.0)	4100 (282)
300 (148)	—	500 (34.4)	3200 (220)	—	500 (34.4)	3200 (220)
350 (176)	—	375 (25.8)	2300 (158)	—	375 (25.8)	2300 (158)
400 (204)	—	250 (17.2)	1400 (96.4)	—	250 (17.2)	1400 (96.4)
450 (232)	—	125 (8.6)	500 (34.4)	—	125 (8.6)	500 (34.4)

### H83 Series

Pressure-temperature ratings for H83 series valves are based on PEEK seats, fluorocarbon FKM O-rings, and reinforced PTFE backup rings.

Low-temperature LH83 series ball valves are available, see page 9.

Material	316 SS				
	End Connections	F2, F4, S4, S6MM	S10MM	S6, S8MM	S8
Temperature, °F (°C)	Working Pressure, psig (bar)				
0 (-17) to 100 (37)	10 000 (689)	8400 (578)	7500 (516)	6700 (461)	6600 (454)
150 (65)	7 500 (516)	7500 (516)	7500 (516)	6700 (461)	6600 (454)
200 (93)	5 000 (344)	5000 (344)	5000 (344)	5000 (344)	5000 (344)
250 (121)	4 100 (282)	4100 (282)	4100 (282)	4100 (282)	4100 (282)
300 (148)	3 200 (220)	3200 (220)	3200 (220)	3200 (220)	3200 (220)
350 (176)	2 300 (158)	2300 (158)	2300 (158)	2300 (158)	2300 (158)
400 (204)	1 400 (96.4)	1400 (96.4)	1400 (96.4)	1400 (96.4)	1400 (96.4)
450 (232)	500 (34.4)	500 (34.4)	500 (34.4)	500 (34.4)	500 (34.4)

## Flow Data at 70°F (20°C)

### 83 Series 2-Way

0.187 in. (4.75 mm) orifice, 1.2 C<sub>v</sub>

Pressure Drop to Atmosphere (Δp) psi (bar)	Air Flow std ft <sup>3</sup> /min (std L/min)	Water Flow U.S. gal/min (L/min)
10 (0.68)	14 (390)	3.8 (14)
50 (3.4)	36 (1000)	8.5 (32)
100 (6.8)	64 (1800)	12 (45)

### H83 Series 2-Way

0.187 in. (4.75 mm) orifice, 1.2 C<sub>v</sub>

Pressure Drop to Atmosphere (Δp) psi (bar)	Air Flow std ft <sup>3</sup> /min (std L/min)	Water Flow U.S. gal/min (L/min)
150 (10.3)	92 (2600)	15 (56)
600 (41.3)	340 (9600)	29 (100)
1000 (68.9)	570 (16 100)	38 (140)

### 83 Series 3-Way

0.187 in. (4.75 mm) orifice, 0.75 C<sub>v</sub>

Pressure Drop to Atmosphere (Δp) psi (bar)	Air Flow std ft <sup>3</sup> /min (std L/min)	Water Flow U.S. gal/min (L/min)
10 (0.68)	8.0 (220)	2.4 (9.0)
50 (3.4)	23 (650)	5.3 (20)
100 (6.8)	40 (1100)	7.5 (28)

### H83 Series 3-Way

0.187 in. (4.75 mm) orifice, 0.75 C<sub>v</sub>

Pressure Drop to Atmosphere (Δp) psi (bar)	Air Flow std ft <sup>3</sup> /min (std L/min)	Water Flow U.S. gal/min (L/min)
150 (10.3)	57 (1600)	9.2 (34)
600 (41.3)	210 (5900)	18 (68)
1000 (68.9)	350 (9900)	24 (90)

## Testing

Every Swagelok trunnion ball valve is factory tested with nitrogen at 1000 psig (69 bar). Seats have a maximum allowable leak rate of 0.1 std cm<sup>3</sup>/min. Shell testing is performed to a requirement of no detectable leakage with a liquid leak detector.

## Low Fugitive Emissions

The American Petroleum Institute's API 641 tests for fugitive emissions to atmosphere for quarter turn ball valves. The tests are conducted at a third party lab and certify that at no point in the test did the valve leak in excess of 100 ppm of methane. Certificates stating that the valve is certified for Low Emissions service are available for the 83 series with Fluorocarbon FKM stem O-rings. For more information, contact your authorized Swagelok sales and service representative.

## Cleaning and Packaging

All Swagelok trunnion ball valves are cleaned and packaged in accordance with Swagelok *Standard Cleaning and Packaging (SC-10)* catalog, [MS-06-62](#). Cleaning and packaging in accordance with Swagelok *Special Cleaning and Packaging (SC-11)* catalog, [MS-06-63](#), to ensure compliance with product cleanliness requirements stated in ASTM G93 Level C are available as an option for 83 series valves, see page 10.

## Materials of Construction

### 83 Series

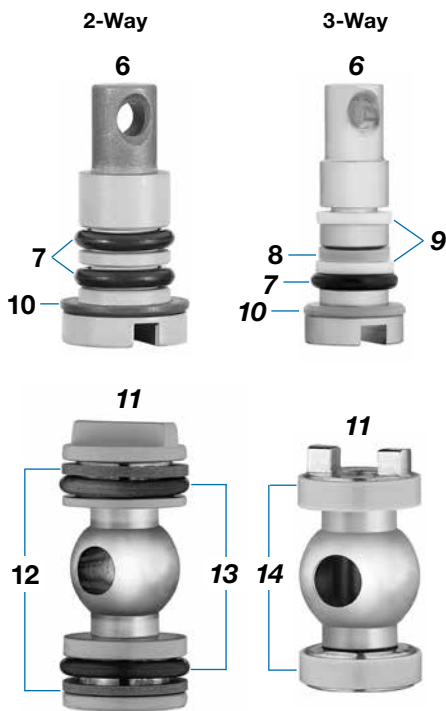
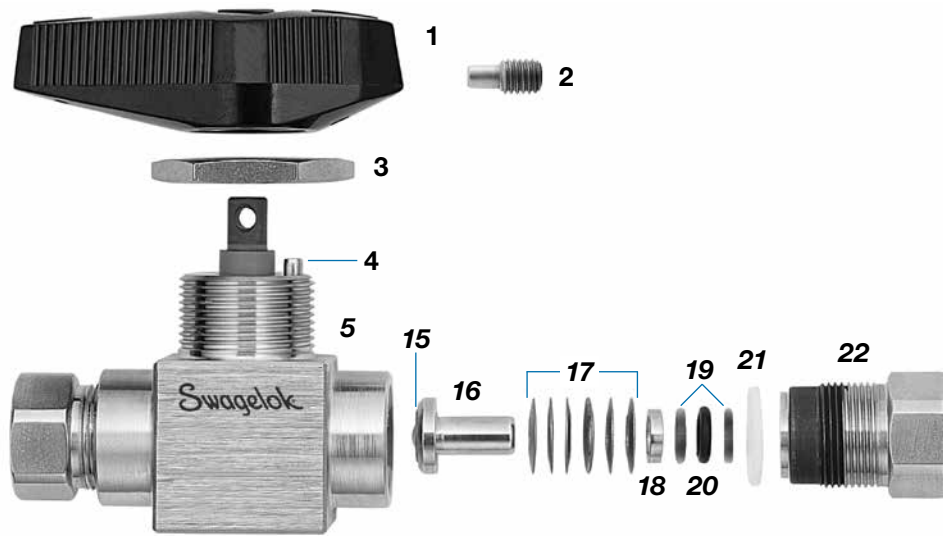

Component	Valve Body Material			
	Stainless Steel		Alloy 400	
	2-Way	3-Way	2-Way	3-Way
	Material Grade/ASTM Specification			
1 Handle	Phenolic with powdered metal 300 series SS insert			
2 Set screw	S17400 SS			
3 Panel nut	316 SS/B783			
4 Stop pins (2-way—2; 3-way—1)	Stainless steel			
5 Body	316 SS/A479		Alloy 400/B164	
6 Stem	316 SS/A276		Alloy 400/B164	
7 Stem O-rings (2-way—2; 3-way—1)	Fluorocarbon FKM			
8 Primary stem backup ring	—	PEEK	—	PEEK
9 Secondary stem backup ring	—	PTFE/D1710	—	PTFE/D1710
10 Stem bearing	Reinforced PTFE	PEEK	Reinforced PTFE	PEEK
11 Ball <sup>①</sup>	316 SS/A276	S21800/A276	Alloy 400/B164	
12 Trunnion backup rings (2)	Reinforced PTFE	—	Reinforced PTFE	—
13 Trunnion O-rings (2)	Fluorocarbon FKM	—	Fluorocarbon FKM	—
14 Trunnion bearings	—	PEEK	—	PEEK
15 Seats (2)	PCTFE, PTFE/D1710, reinforced nylon, or PEEK			
16 Seat carriers (2)	316 SS/A276		Alloy 400/B164	
17 Seat springs (6 with PTFE; 12 with all others)	Alloy X-750/AMS 5542			
18 Seat carrier guides (2)	316 SS/A276		Alloy 400/B164	
19 Seat carrier backup rings (4)	Reinforced PTFE			
20 Seat carrier O-rings (2)	Fluorocarbon FKM			
21 End screw seals (2)	PTFE/D1710			
22 End screws (2)	316 SS/A479		Alloy 400/B164	
Wetted lubricants	Fluorinated-based (all valves); tungsten disulfide additive (valves with PEEK seats)			
Nonwetted lubricant	Molybdenum disulfide with hydrocarbon binder coating			

Wetted components listed in *italics*.

① Ball trunnions are PTFE coated in 83 series 2-way valve.

## Materials of Construction

### H83 Series

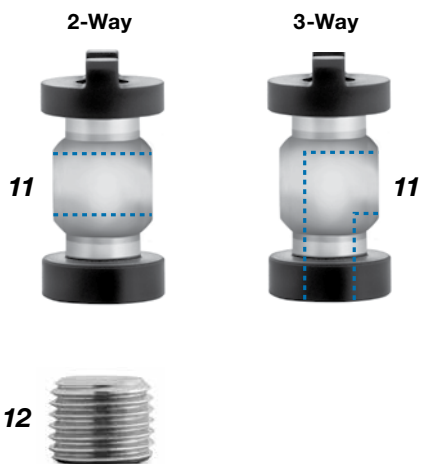
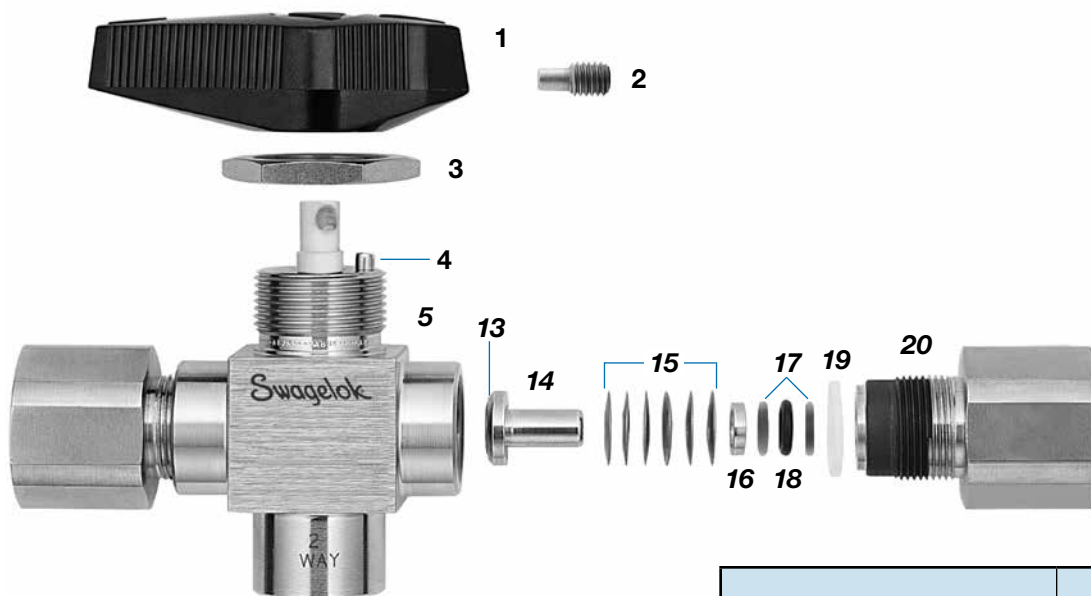

Component	2-Way	3-Way
	Material Grade/ ASTM Specification	
1 Handle	Phenolic with powdered metal 300 series SS insert	
2 Set screw	S17400 SS	
3 Panel nut	316 SS/B783	
4 Stop pin (2-way—2; 3-way—1)	Stainless steel	
5 Body	316 SS/A479	
6 Stem	316 SS/A276	
7 Stem O-ring	Fluorocarbon FKM	
8 Primary stem backup ring	PEEK	
9 Secondary stem backup ring	PTFE/D1710	
10 Stem bearing	PEEK	
11 Ball <sup>①</sup>	S21800/A276	
12 Plug (2-way only)	316 SS/A276	—
13 Seats (2)	PEEK	
14 Seat carriers (2)	316 SS/A276	
15 Seat springs (12)	Alloy X-750/AMS 5542	
16 Seat carrier guides (2)	316 SS/A276	
17 Seat carrier backup rings (4)	Reinforced PTFE	
18 Seat carrier O-rings (2)	Fluorocarbon FKM	
19 End screw seals (2)	PTFE/D1710	
20 End screws (2)	316 SS/A479	
Wetted lubricants	Tungsten disulfide and fluorinated-based	
Nonwetted lubricant	Molybdenum disulfide with hydrocarbon binder coating	

Wetted components listed in *italics*.

① Ball trunnions are Xylan® coated.

## Ordering Information and Dimensions

Dimensions, in inches (millimeters), are for reference only and are subject to change. Dimensions shown with Swagelok tube fitting nuts finger-tight.

**83 Series 2-Way**

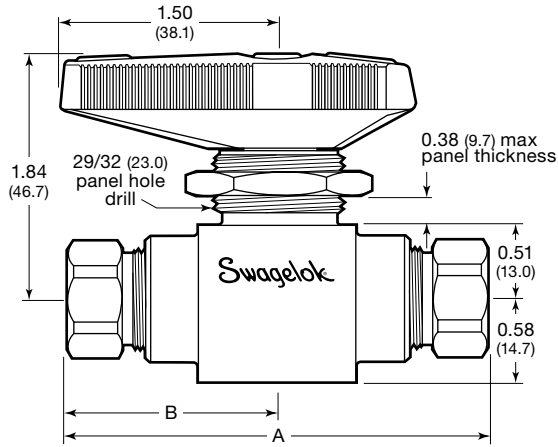

**83 Series 3-Way**

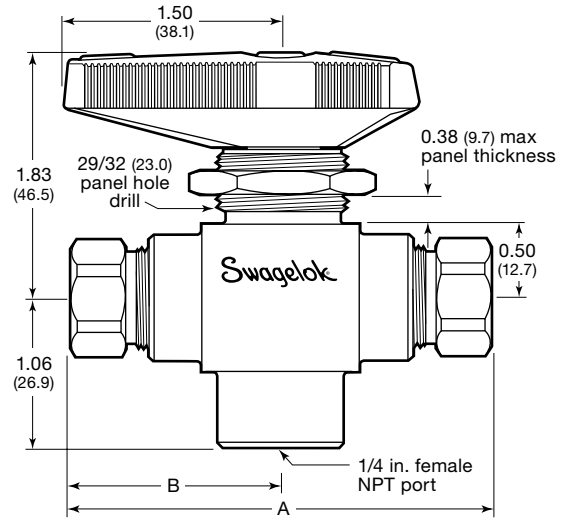

**H83 Series**

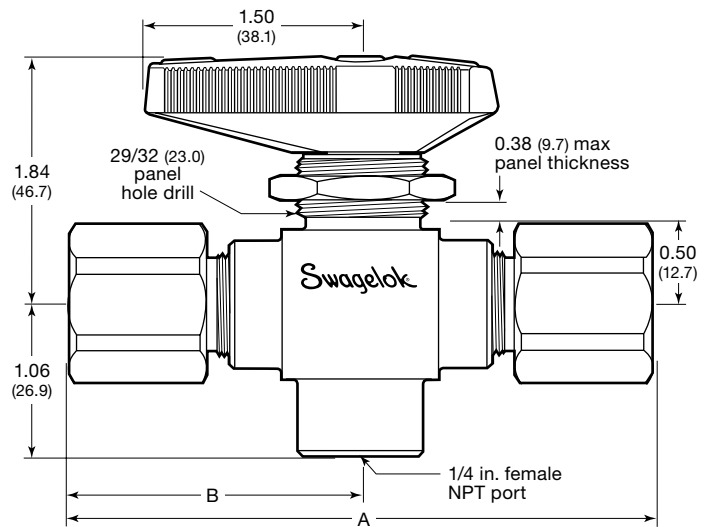

## Ordering Information and Dimensions

### 83 Series

Select a valve ordering number from the table below.

Valve ordering numbers specify stainless steel material. To order valves of alloy 400 material, replace **SS** in the ordering number with **M**.

Example: **M-83KF2**

Valve ordering numbers specify a PCTFE seat. To order valves with other seat materials, replace **K** in the ordering number with a seat material designator.

Seat Material	Designator
PTFE	T
Reinforced nylon	N
PEEK	P

Example: **SS-83TF2**

### H83 Series

Select a valve ordering number from the table below.

End Connections		Flow Coefficient (C <sub>v</sub> )	83 Series Valve Ordering Number	H83 Series Valve Ordering Number	Dimensions, in. (mm)	
Type	Size				A	B
<b>2-Way Valve, 0.187 in. (4.75 mm) Orifice</b>						
Female NPT	1/8 in.	1.2	SS-83KF2	SS-H83PF2	2.94 (74.7)	1.47 (37.3)
	1/4 in.	1.0	SS-83KF4	—	2.94 (74.7)	1.47 (37.3)
			—	SS-H83PF4	3.93 (99.8)	1.97 (50.0)
	1/2 in. <sup>①</sup>	1.2	SS-83KF8	—	4.25 (108)	2.13 (54.1)
Fractional Swagelok tube fitting	1/4 in.	1.6	SS-83KS4	SS-H83PS4	4.14 (105)	2.07 (52.6)
	3/8 in.	1.4	SS-83KS6	SS-H83PS6	4.39 (112)	2.19 (55.6)
	1/2 in. <sup>①</sup>	1.0	SS-83KS8	SS-H83PS8	4.60 (117)	2.30 (58.4)
Metric Swagelok tube fitting	6 mm	1.6	SS-83KS6MM	SS-H83PS6MM	4.14 (105)	2.07 (52.6)
	8 mm	1.5	SS-83KS8MM	SS-H83PS8MM	4.15 (105)	2.07 (52.6)
	10 mm	1.3	SS-83KS10MM	SS-H83PS10MM	4.41 (112)	2.20 (55.9)
	12 mm <sup>①</sup>	1.0	SS-83KS12MM	SS-H83PS12MM	4.60 (117)	2.30 (58.4)
<b>3-Way Valve, 0.187 in. (4.75 mm) Orifice</b>						
Female NPT <sup>②</sup>	1/8 in.	0.75	SS-83XKF2	SS-H83XPF2	2.94 (74.7)	1.47 (37.3)
	1/4 in.		SS-83XKF4	—	2.94 (74.7)	1.47 (37.3)
			—	SS-H83XPF4	3.93 (99.8)	1.97 (50.0)
Fractional Swagelok tube fitting <sup>②</sup>	1/4 in.		SS-83XKS4	SS-H83XPS4	4.14 (105)	2.07 (52.6)
	3/8 in.		SS-83XKS6	SS-H83XPS6	4.39 (112)	2.19 (55.6)
	1/2 in. <sup>①</sup>		SS-83XKS8	SS-H83XPS8	4.60 (117)	2.30 (58.4)
Metric Swagelok tube fitting <sup>②</sup>	6 mm		SS-83XKS6MM	SS-H83XPS6MM	4.14 (105)	2.07 (52.6)
	8 mm		SS-83XKS8MM	SS-H83XPS8MM	4.15 (105)	2.07 (52.6)
	10 mm		SS-83XKS10MM	SS-H83XPS10MM	4.41 (112)	2.20 (55.9)
	12 mm <sup>①</sup>	SS-83XKS12MM	SS-H83XPS12MM	4.60 (117)	2.30 (58.4)	

For more information about pressure ratings of valves with tube fitting end connections, refer to *Tubing Data* catalog, [MS-01-107](#).

① Not recommended for panel mounting.

② Bottom port of all 3-way valves is 1/4 in. female NPT.

## Options and Accessories

### 83 and H83 Series Handles

Black phenolic handles are standard. Colored phenolic, and 316 stainless steel bar handles are available. To order, add a handle designator to the valve ordering number.

Example: SS-83KF2-**RD**

#### Handle Kits

Handle kits contain a handle and set screw.

Standard black phenolic handle kit ordering number:

**PH-5K-83-BK**

To order handles in other colors, replace **-BK** in the kit ordering number with a handle designator.

Example: PH-5K-83-**RD**

Stainless steel bar handle kit ordering number: **SS-5K-83**

#### Locking Handle

The stainless steel locking handle accommodates shackle diameters from 1/4 to 5/16 in. (6.4 to 7.9 mm) and a 3/4 in. (19.0 mm) minimum shackle length. It can lock 83 series and H83 series 2-way and 3-way valves in the open or closed position.

To order a valve with a factory-assembled locking handle, add **-LH** to a valve ordering number.

Examples: SS-83KS8-**LH**

SS-83XKS8-**LH**

#### Locking Handle Kits

The stainless steel locking handle kit is available for replacing an existing phenolic or stainless steel bar handle; it cannot be used to replace an existing oval handle. The kit includes a locking handle, lock plate, set screw, and instructions.

Kit ordering number: **SS-5K-83LH**



Handle	Designator
Black phenolic	-BK
Blue phenolic	-BL
Green phenolic	-GR
Orange phenolic	-OG
Red phenolic	-RD
Yellow phenolic	-YW
Stainless steel bar	-SH

### 83 Series Seal Kits

Seal kits contain components of the same materials as new components. See **Materials of Construction**, page 4, or **Low-Temperature Service**, page 9.

For a complete ordering number, add a seat material designator to a basic seal kit ordering number.

Example: SS-9K-83K

Seat Material	Designator
PEEK	P
PCTFE	K
PTFE	T
Reinforced nylon	N

Valve Series	Basic Seal Kit Ordering Number	Kit Contents
83 2-way	SS-9K-83	O-rings, stem bearing, ball, seat subassemblies (seats and seat carriers), seat springs, end screw seals, lubricant, lubricant Material Safety Data Sheet (MSDS), instructions
Low-temperature 83 2-way	SS-9K-L83	
83 3-way	SS-9K-83X	Stem, handle set screw, O-rings, backup rings, bearings, ball, seat subassemblies (seats and seat carriers), seat springs, end screw seals, lubricant, lubricant MSDS, instructions
Low-temperature 83 3-way	SS-9K-L83X	

Seal kit ordering numbers specify stainless steel material. For alloy 400 material, replace **SS** with **M** for in the basic ordering number.

Example: **M-9K-83K**

### H83 Series Seal Kits

Seal kits contain components of the same materials as new components. See **Materials of Construction**, page 5, or **Low-Temperature Service**, page 9.

Valve Series	Seal Kit Ordering Number	Kit Contents
H83 2-way	SS-9K-H83P	Stem, handle set screw, O-rings, backup rings, stem bearing, ball, seat subassemblies (seats and seat carriers), seat springs, end screw seals, lubricant, lubricant MSDS, instructions
Low-temperature H83 2-way	SS-9K-LH83P	
H83 3-way	SS-9K-H83XP	
Low-temperature H83 3-way	SS-9K-LH83XP	

### 83 Series Vent Options

A downstream or upstream ball vent is available in 83 series 2-way valves. The vent port in the ball does not intersect the main flow passage, ensuring no leakage of system media from the vent port. When the valve is open, flow is straight through. The pressure rating with a ball vent is reduced to 500 psig (34.4 bar).

#### Downstream (DV) Vent

When a downstream-vented valve is closed, full shutoff occurs at the upstream seat. Downstream system media passes through the vent hole in the ball trunnion and vents to atmosphere through the bottom of the trunnion.

To order, insert **DV** into the valve ordering number.

Example: SS-83K**DV**F2

#### Upstream (UV) Vent

When an upstream-vented valve is closed, full shutoff occurs at the downstream seat. Upstream system media passes through the vent hole in the ball trunnion and vents to atmosphere through the bottom of the trunnion.

To order, insert **UV** into the valve ordering number.

Example: SS-83K**UV**F2



## Service Options

### 83 and H83 Series Low-Temperature Service

Trunnion ball valves for low-temperature service, with a temperature rating of  $-40$  to  $200^{\circ}\text{F}$  ( $-40$  to  $93^{\circ}\text{C}$ ), are available. Low-temperature valves have low-temperature Buna C O-rings. All other materials and ratings are the same as those of standard valves.

To order a valve for low-temperature service, insert **L** into the valve ordering number.

Example: SS-L83KF2

### L83 Series Pressure-Temperature Ratings

Material	316 SS			Alloy 400		
	Seat Material	PCTFE, Nylon	PTFE	PEEK	PCTFE, Nylon	PTFE
Temperature, $^{\circ}\text{F}$ ( $^{\circ}\text{C}$ )	Working Pressure, psig (bar)					
$-40$ ( $-40$ ) to $100$ (37)	6000 (413)	1500 (103)	6000 (413)	5000 (344)	1500 (103)	5000 (344)
150 (65)	3000 (206)	1125 (77.5)	5800 (399)	3000 (206)	1125 (77.5)	4690 (323)
200 (93)	2000 (137)	750 (51.6)	5000 (344)	2000 (137)	750 (51.6)	4390 (302)

### LH83 Series Pressure-Temperature Ratings

Material	316 SS				
	End Connections	F2, F4, S4, S6MM	S10MM	S6, S8MM	S8
Temperature, $^{\circ}\text{F}$ ( $^{\circ}\text{C}$ )	Working Pressure, psig (bar)				
$-40$ ( $-40$ ) to $100$ (37)	10 000 (689)	8400 (578)	7500 (516)	6700 (461)	6600 (454)
150 (65)	7 500 (516)	7500 (516)	7500 (516)	6700 (461)	6600 (454)
200 (93)	5 000 (344)	5000 (344)	5000 (344)	5000 (344)	5000 (344)

### 83 Series Valves With ECE R110-Type Approval

#### $-40$ to $185^{\circ}\text{F}$ ( $-40$ to $85^{\circ}\text{C}$ ) Temperature Range

Stainless steel 83 series 2-way and 3-way valves with PEEK seats and Buna C O-rings are available with ECE R110-type approval for use in alternative fuel service.

- Temperature rating:  $-40$  to  $185^{\circ}\text{F}$  ( $-40$  to  $85^{\circ}\text{C}$ )
- Pressure rating within the range: 3770 psig (260 bar)

To order, add **-11354** to a PEEK-seated, low-temperature valve ordering number.

Examples: SS-L83PS8-**11354**  
SS-L83XPS8-**11354**

#### $-40$ to $248^{\circ}\text{F}$ ( $-40$ to $120^{\circ}\text{C}$ ) Temperature Range

Stainless steel 83 series 2-way and 3-way valves with PEEK seats and low-temperature fluorocarbon FKM O-rings are available with ECE R110-type approval for use in alternative fuel service.

- Temperature rating:  $-40$  to  $248^{\circ}\text{F}$  ( $-40$  to  $120^{\circ}\text{C}$ )
- Pressure rating within the range: 3770 psig (260 bar)

To order, add **-21265** to a PEEK-seated, low-temperature valve ordering number.

Examples: SS-L83PS8-**21265**  
SS-L83XPS8-**21265**

### Additional Valve Materials

Alloy 625, alloy 825, and Alloy 2507 super duplex stainless steel materials are available for 83 series valves. Refer to *Trunnion Ball Valves—Special Alloy Materials* catalog, [MS-02-357](#).

## Service Options

### 83 Series for “Fast Fill” CNG Filling Station Applications

Stainless steel 83 series 3-way manual valves are available for use in a variety of filling station applications. These valves improve performance in demanding high-cycle, high-pressure applications, and prevent the need for frequent rebuilds.

Features include:

- A directional installation with 90 degree actuation for ease of operation during filling
- 3-way design with vent port for ease of venting after fill
- PEEK seats to reduce maintenance required in high-cycle applications
- Cycle life test report available upon request

Example: SS-83DXLPF4  
SS-L83DXLPF4

Note: The handle set screw used in this valve is longer than the standard 83 series handle set screw and thus is not interchangeable.

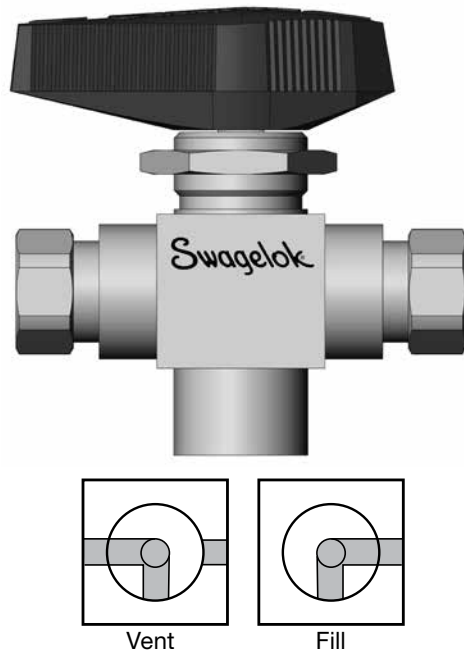

### 83DXL Valve Seal Kit

Seal kits contain components of the same materials as new components. See **Materials of Construction**, page 4, or **Low-Temperature Service**, page 9.

Seal kit contains stem, handle set screw, O-rings, backup rings, bearings, ball, seat subassemblies (PEEK seats and seat carriers), seat springs, end screw seals, lubricant, lubricant MSDS, and instructions.

Example: SS-9K-83DXLP

### 83 Series Special Cleaning and Packaging (SC-11)

To order optional cleaning and packaging in accordance with Swagelok *Special Cleaning and Packaging (SC-11)* catalog, [MS-06-63](#), to ensure compliance with product cleanliness requirements stated in ASTM G93 Level C for 83 series valves, add **-SC11** to the valve ordering number.

Example: SS-83KF2-**SC11**

### Oxygen Service Hazards

For more information about hazards and risks of oxygen-enriched systems, see the Swagelok *Oxygen System Safety* technical report, [MS-06-13](#).

### FFKM O-Ring Material

An optional FFKM O-ring material is available for 83 and H83 Series ball valves.

- Temperature rating for 83 Series with FFKM O-ring material: 25 to 250°F (-3 to 121°C)
- Temperature rating for H83 Series with FFKM O-ring material: 36 to 250°F (3 to 121°C)

To order, add **-KZ** to the valve ordering number.

Example: SS-83PS4-**KZ**

## Pneumatic Actuators



Swagelok rack and pinion pneumatic actuators are compact, lightweight, easily mountable, and can be operated with standard shop air. They are available in spring-return and double-acting modes. On-off (2-way) valves require 90° actuation; switching (3-way) valves require 180° actuation.

For technical data, including pressure-temperature ratings and materials of construction, refer to *Ball Valve Actuation Options* catalog, [MS-02-343](#).

**⚠ Actuated assemblies must be properly aligned and supported. Improper alignment or inadequate support of the actuated assembly may result in leakage or premature valve failure.**

### Pressure-Temperature Ratings

Actuator Service	Actuator Service Designator	Temperature Range °F (°C)	Maximum Actuator Pressure, psig (bar)	
			At 100°F (37°C)	At Maximum Temperature
Standard	—	-20 to 200 (-28 to 93)	200 (13.7)	165 (11.3)
High temperature	HT	0 to 400 (-17 to 204)		100 (6.8)
Low temperature	LT	-40 to 200 (-40 to 93)		165 (11.3)
Nonfluorocarbon	NF	-20 to 200 (-28 to 93)		165 (11.3)

### 83 Series Actuator Pressure at Maximum System Pressure

Based on valve performance using pressurized air or nitrogen.

Valve Series	Actuator Model	Actuator Model Designator	System Pressure psig (bar)	Actuation Modes			
				Double Acting		Spring Return	
				Single	Dual	Single	Dual
				Minimum Actuator Pressure, psig (bar)			
83 2-way	31 (90°)	-31	1500 (103)	30 (2.1)	50 (3.5)	70 (4.9)	80 (5.6)
			6000 (413)	35 (2.5)	60 (4.2)	75 (5.2)	—
	33 (90°)	-33	1500 (103)	15 (1.1)	20 (1.4)	65 (4.5)	70 (4.9)
			6000 (413)	20 (1.4)	25 (1.8)	75 (5.2)	75 (5.2)
83 3-way	51 (180°)	-51	1500 (103)	35 (2.5)	60 (4.2)	75 (5.2)	—
			6000 (413)	45 (3.2)	85 (5.8)	—	—
	53 (180°)	-53	1500 (103)	15 (1.1)	25 (1.8)	70 (4.9)	75 (5.2)
			6000 (413)	20 (1.4)	35 (2.5)	75 (5.2)	—

### H83 Series Actuator Pressure at Maximum System Pressure

Based on valve performance using pressurized air or nitrogen.

Valve Series	Actuator Model	Actuator Model Designator	System Pressure psig (bar)	Actuation Modes			
				Double Acting		Spring Return	
				Single	Dual	Single	Dual
				Minimum Actuator Pressure, psig (bar)			
H83 2-way	31 (90°)	-31	1 500 (103)	35 (2.5)	60 (4.2)	—	—
			6 000 (413)	45 (3.2)	85 (5.9)		
			10 000 (689)	55 (3.8)	100 (6.9)		
	33 (90°)	-33	1 500 (103)	15 (1.1)	25 (1.8)	70 (4.9)	75 (5.2)
			6 000 (413)	20 (1.4)	35 (2.5)	75 (5.2)	85 (5.9)
			10 000 (689)	25 (1.8)	45 (3.2)	80 (5.6)	90 (6.3)
H83 3-way	51 (180°)	-51	1 500 (103)	35 (2.5)	60 (4.2)	—	—
			6 000 (413)	45 (3.2)	85 (5.9)		
			10 000 (689)	55 (3.8)	100 (6.9)		
	53 (180°)	-53	1 500 (103)	15 (1.1)	25 (1.8)	70 (4.9)	—
			6 000 (413)	20 (1.4)	35 (2.5)	75 (5.2)	
			10 000 (689)	25 (1.8)	45 (3.2)	80 (5.6)	

## Pneumatic Actuators

### Ordering Information

#### Factory-Assembled Valves with Actuators

#### Typical Ordering Number

A    B C D  
**SS - 83KF2 -31 D HT**

#### **A** Valve Ordering Number

#### **B** Actuator Model

Based on valve series, flow pattern, and actuation mode, select an actuator designator. See **Actuator Pressure at Maximum System Pressure** tables, page 11.

- 31 = 90° actuation
- 33 = 90° actuation
- 51 = 180° actuation
- 53 = 180° actuation

#### **C** Actuation Mode

- C** = Spring return, normally closed
- D** = Double acting
- O** = Spring return, normally open
- S** = Spring return, 3-way valves

#### **D** Actuator Service

- HT** = High temperature
- LT** = Low temperature
- NF** = Nonfluorocarbon
- None** = Standard

*For dual-mounted assemblies (two valves mounted to one actuator), add **DM** to the ordering number.*

*Example: SS-83KF2-31DDM*

#### Kits for Field Assembly

Order one actuator kit and one mounting bracket kit for each valve.

#### Actuator Kit Typical Ordering Number

A    B    C  
**MS-1 31 - DA -HT**

#### **A** Actuator Model

Based on valve series, flow pattern, and actuation mode, select an actuator designator. See **Actuator Pressure at Maximum System Pressure** tables, page 11.

- 31** = 90° actuation
- 33** = 90° actuation
- 51** = 180° actuation
- 53** = 180° actuation

#### **B** Actuation Mode

- DA** = Double acting
- SR** = Spring return

#### **C** Actuator Service

- HT** = High temperature
- LT** = Low temperature
- NF** = Nonfluorocarbon
- None** = Standard

#### Mounting Bracket Kits

Mounting bracket kits contain:

- 316 stainless steel mounting bracket
- 316 stainless steel coupling
- stainless steel stop pin (90° actuation, 2 roll pins; 180° actuation, 1 roll pin)
- S17400 set screw
- instructions.

Valve Series	Actuator Model	Mounting Bracket Kit Ordering Number
83, H83 2-way	31 (90°)	SS-MB-83-131
	33 (90°)	SS-MB-83-133
83, H83 3-way	51 (180°)	SS-MB-83-131
	53 (180°)	SS-MB-83-133

## Pneumatic Actuators

### Dimensions

Dimensions, in inches (millimeters), are for reference only and are subject to change.

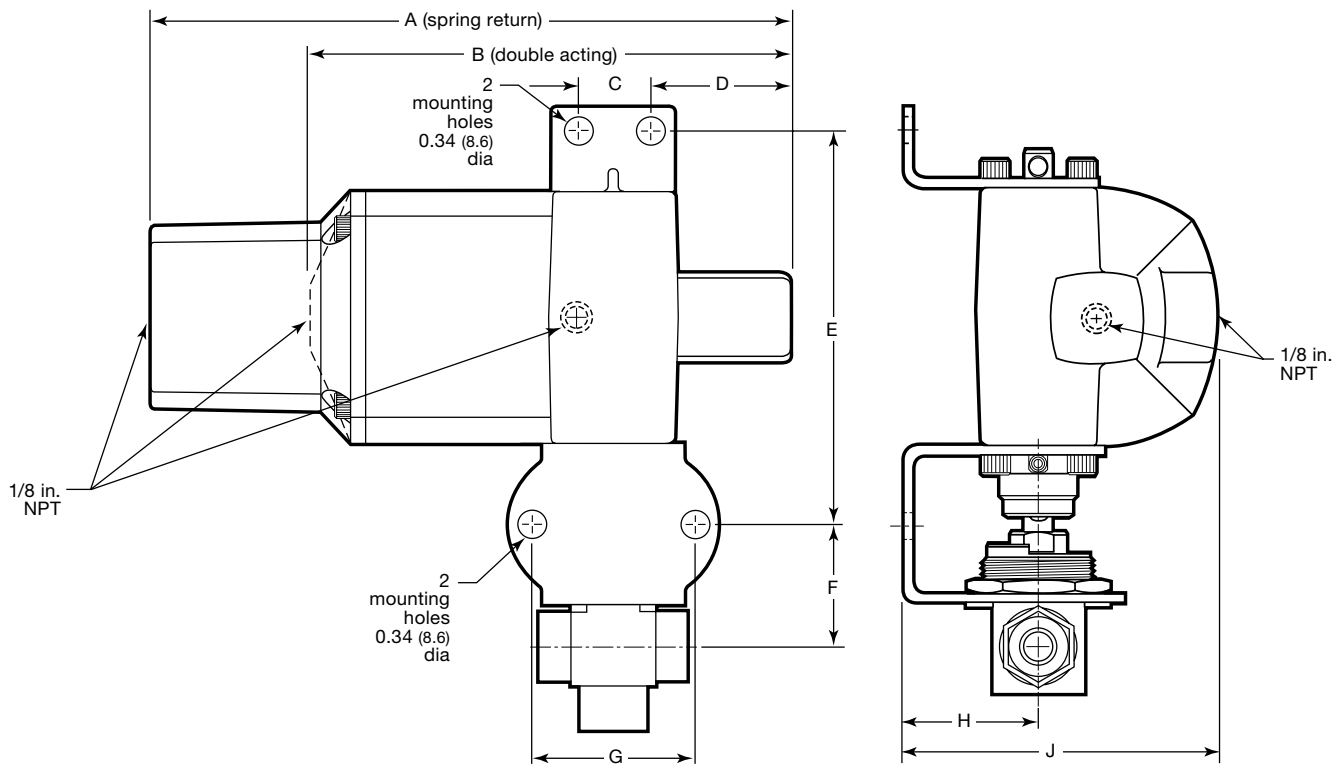

Actuator Model	Dimensions, in. (mm)								
	A	B	C	D	E	F	G	H	J
31 (90°)	4.91	4.09	0.63	1.15	3.64	1.28	2.00	1.31	3.04
51 (180°)	(125)	(104)	(16.0)	(29.2)	(92.5)	(32.5)	(50.8)	(33.3)	(77.2)
33 (90°)	7.86	5.89	0.88	1.73	4.88	1.51	2.00	1.75	4.07
53 (180°)	(200)	(150)	(22.4)	(44.0)	(124)	(38.4)	(50.8)	(44.4)	(103)

## ISO 5211-Compliant Pneumatic Actuators



Swagelok ISO 5211-compliant rack and pinion pneumatic actuators are suitable for general applications. They are available in spring-return and double-acting modes. On-off (2-way) valves require 90° actuation; switching (3-way) valves require 180° actuation.

Valve-actuator assemblies on this page are based on:

- maximum valve pressure
- ambient temperature (50 to 100°F [10 to 37°C])

For technical data, including actuator materials of construction and weight, refer to *Ball Valve Actuation Options* catalog, [MS-02-343](#).

For additional information on selecting and sizing ISO 5211-compliant actuators, refer to *Actuated Ball Valve Selection Guide—ISO 5211-Compliant Actuator Mounting Bracket Kits* catalog, [MS-02-136](#).

**⚠ Actuated assemblies must be properly aligned and supported. Improper alignment or inadequate support of the actuated assembly may result in leakage or premature valve failure.**

### Pressure-Temperature Ratings

Maximum actuator pressure is 116 psig (8.0 bar). See **Minimum Actuator Pressure** table below for minimum actuator pressures.

Actuator Service	Actuator Service Designator	Temperature Range °F (°C)
Standard	—	-40 to 176 (-40 to 80)
High temperature	HT	5 to 302 (-15 to 150)

### 83 Series Minimum Actuator Pressure

Valve Series	Actuator Model	Spring Return Model Designators		Double Acting Model Designator	Actuation Mode	
		Normally Closed	Normally Open		Spring Return	Double Acting
					Minimum Actuator Pressure, psig (bar)	
83 2-way	A10 (90°)	—	—	-A10D	—	36 (2.5)
	A15 (90°)	-A15C3	-A15O3	-A15D	43 (3.0)	36 (2.5)
83 3-way	A15 (180°)	—	—	-A15XD	—	36 (2.5)

### H83 Series Minimum Actuator Pressure

Valve Series	Actuator Model	Spring Return Model Designators		Double Acting Model Designator	Actuation Mode	
		Normally Closed	Normally Open		Spring Return	Double Acting
					Minimum Actuator Pressure, psig (bar)	
H83 2-way	A10 (90°)	—	—	-A10D	—	43 (3.0)
	A15 (90°)	-A15C3	-A15O3	-A15D	43 (3.0)	36 (2.5)
H83 3-way	A15 (180°)	—	—	-A15XD	—	36 (2.5)

## ISO 5211-Compliant Pneumatic Actuators

### Ordering Information

#### Factory-Assembled Valves with Actuators

##### Typical Ordering Number

A      B      C  
**SS-83KF2 -A15D HT**

##### **A** Valve Ordering Number

##### **B** Actuator Model

Based on valve series, flow pattern, and actuation mode, select an actuator designator. See **Minimum Actuator Pressure** tables, page 14.

##### **C** Actuator Service

**HT** = High temperature  
**None** = Standard

#### Kits for Field Assembly

Order one actuator kit and one mounting bracket kit for each valve.

##### Actuator Kit Typical Ordering Number

A    B    C    D  
**MS - A15 - 3 - DIN -HT**

##### **A** Actuator Model

Based on valve series, flow pattern, and actuation mode, select an actuator. See **Minimum Actuator Pressure** tables, page 14.

**A10** = A10  
**A15** = A15

##### **B** Actuation Mode

**DA** = Double acting (2-way valves)  
**XDA** = Double acting (3-way valves)  
**3** = Spring return

##### **C** Coupling Drive Type

DIN

##### **D** Actuator Service

**-HT** = High temperature  
**None** = Standard

#### Mounting Bracket Kits

Swagelok ISO 5211 mounting bracket kits contain:

- 316 stainless steel mounting bracket
- four A4 stainless steel socket head cap screws (A4 is approximately equivalent to AISI 316.)
- 316 stainless steel coupling
- A4 stainless steel set screw
- instructions.

Kit ordering number: **SS-MB-83-F04-11DIN-M**

## ISO 5211-Compliant Pneumatic Actuators

### Dimensions

Dimensions, in inches (millimeters), are for reference only and are subject to change.

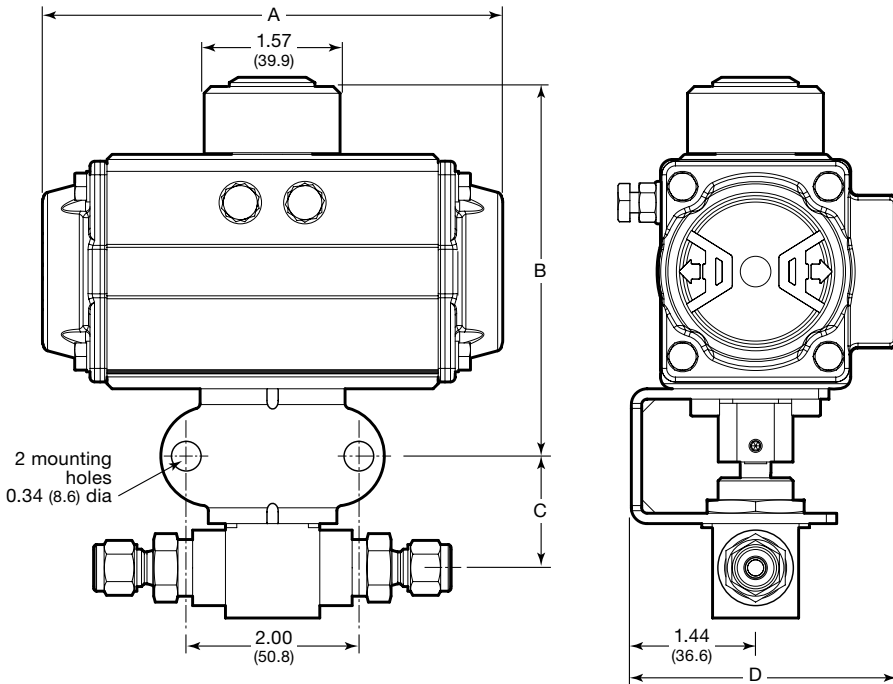

Valve Series	Actuator Model	Dimensions, in. (mm)			
		A	B	C	D
83, H83 2-way	A10 (90°)	4.65 (118)	4.17 (106)	1.29 (32.8)	2.84 (72.1)
	A15 (90°)	5.33 (135)	4.17 (106)	1.29 (32.8)	3.09 (78.5)
83, H83 3-way	A15 (180°)	7.55 (192)	4.28 (109)	1.29 (32.8)	3.09 (78.5)

### Options for ISO 5211-Compliant and Swagelok Pneumatic Actuators

Swagelok offers a range of accessories to enhance instrumentation and process ball valve performance and control, including solenoid valves, limit switches, and position sensors. Factory assemblies and kits for field assembly are available.

Refer to *Ball Valve Actuation Options* catalog, [MS-02-343](#), for additional information.



### Electric Actuators

Swagelok electric actuators are rugged and lightweight, and connect alternating- or direct-current power sources.

Refer to *Electric Actuators—141 and 142 Series* catalog, [MS-01-35](#), for additional information.

#### Safe Product Selection

**When selecting a product, the total system design must be considered to ensure safe, trouble-free performance. Function, material compatibility, adequate ratings, proper installation, operation, and maintenance are the responsibilities of the system designer and user.**

### Warranty Information

Swagelok products are backed by The Swagelok Limited Lifetime Warranty. For a copy, visit [swagelok.com](http://swagelok.com) or contact your authorized Swagelok representative.

#### **⚠ WARNING**

**Do not mix/interchange Swagelok products or components not governed by industrial design standards, including Swagelok tube fitting end connections, with those of other manufacturers.**