

高纯 PFA 细牙螺纹扩口接头



- 可用于尺寸为 1/4, 3/8, 1/2, 3/4 和 1 in. 的卡套管
- PFA 和 PVDF 螺母选购件
- 多种配置

目录

直通接头

联合接头

- 联合接头 84
- 变径联合接头 84
- 穿板接头 85
- 穿板变径接头 85



外螺纹接头

- NPT 85
- 穿板 NPT 85



内螺纹连接接头

- NPT 86



空间节省型变径接头

- 内螺纹扩口 86
- 外螺纹到内螺纹扩口 86



端帽, 堵塞和螺母

- 扩口堵塞 86
- 螺母 86
- 扩口端帽和螺母 87
- 穿板螺母 87



90° 弯头

联合接头

- 联合接头 87
- 变径联合接头 87



外螺纹

- NPT 87

内螺纹

- NPT 88

空间节省型弯头

联合接头

- 内螺纹扩口 88
- 外螺纹到内螺纹扩口 88
- 变径内螺纹扩口 88



空间节省型弯头

联合接头

- 内螺纹扩口 89
- 外螺纹到内螺纹扩口 89
- 外螺纹 NPT 89



三通接头

联合接头

- 联合接头 89
- 变径联合接头 90



外螺纹

- 支管, NPT 90
- 直通, NPT 90

空间节省型三通

联合接头

- 联合接头 90
- 直通 91
- 直通, 直通 91
- 支管 91
- 支管, 直通 91



PVDF 多重扩口接头

- 穿板接头 92
- 外螺纹 NPT 92
- 过渡接头 92



PVDF 过渡接头 92

双重防泄漏接头 93



关于更多配置和定制接头,
请与授权的世伟洛克代表联系。

特点

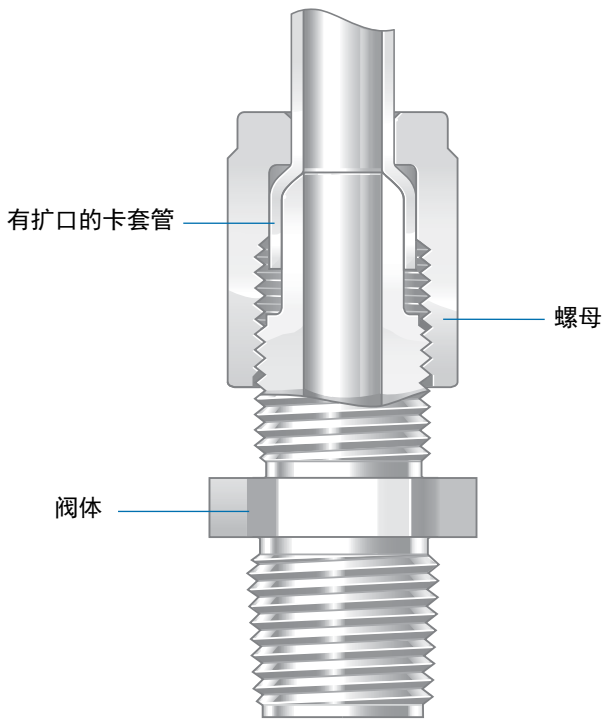

卡套管接头

压力—温度额定值

卡套管尺寸	1/4 in.	3/8 in.	1/2 in.	3/4 in.	1 in.
温度, °C (°F)	工作压力, psig (bar)				
带 PVDF 螺母的高纯 PFA 本体					
23 (75)	275 (18.9)	235 (16.1)	190 (13.0)	110 (7.5)	80 (5.5)
148 (300)	75 (5.1)	75 (5.1)	50 (3.4)	30 (2.0)	15 (1.0)
带 PFA 螺母的高纯 PFA 本体					
23 (75)	275 (18.9)	235 (16.1)	190 (13.0)	110 (7.5)	80 (5.5)
176 (350)	50 (3.4)	50 (3.4)	40 (2.7)	20 (1.3)	15 (1.0)
PVDF 本体和螺母					
23 (75)	275 (18.9)	235 (16.1)	190 (13.0)	110 (7.5)	80 (5.5)

包装

世伟洛克® (Swagelok®) 高纯 PFA 细牙螺纹扩口接头是按照 SEMI F57-0301 包装的。

订购信息与尺寸

- 尺寸以英寸为单位表示，仅供参考，可能有变动。
- PFA 接头的标准配置为 PVDF 螺母。要订购带 PFA 螺母的 PFA 接头，请把订购号内的 **1** 替换为 **3**。
例如: PFA4-4-FTF-6-1 (带 PVDF 螺母)
PFA4-4-FTF-6-3 (带 PFA 螺母)

直通接头

联合接头

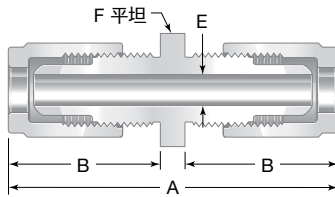

联合接头

卡套管 外径 in.	订购号	尺寸, in.			
		A	B	E	F
1/4	PFA4-4-FTF-6-1	2.49	1.15	0.15	11/16
3/8	PFA4-6-FTF-6-1	2.71	1.25	0.25	13/16
1/2	PFA4-8-FTF-6-1	2.93	1.35	0.38	15/16
3/4	PFA4-12-FTF-6-1	3.25	1.50	0.63	1 3/16
1	PFA4-16-FTF-6-1	3.71	1.71	0.88	1 7/16

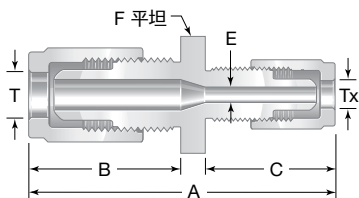

变径联合接头

卡套管外径, in.		订购号	尺寸, in.				
T	Tx		A	B	C	E	F
3/8	1/4	PFA4-6-FTF-6-4-1	2.69	1.25	1.15	0.15	13/16
1/2	3/8	PFA4-8-FTF-6-6-1	2.89	1.35	1.25	0.25	15/16
3/4	1/2	PFA4-12-FTF-6-8-1	3.14	1.50	1.35	0.38	1 3/16
1	3/4	PFA4-16-FTF-6-12-1	3.51	1.71	1.50	0.66	1 7/16

直通接头

联合接头

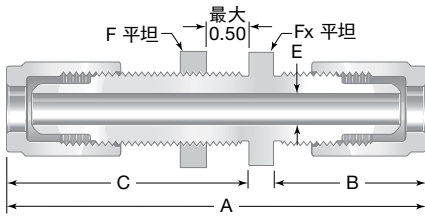

穿板接头

卡套管 外径 in.	订购号	尺寸, in.					
		A	B	C	E	F	Fx
1/4	PFA4-4-FTF-61-1	3.27	1.15	1.93	0.15	3/4	11/16
3/8	PFA4-6-FTF-61-1	3.49	1.25	2.03	0.25	15/16	13/16
1/2	PFA4-8-FTF-61-1	3.71	1.35	2.13	0.38	1 1/16	15/16
3/4	PFA4-12-FTF-61-1	4.03	1.50	2.28	0.63	1 5/16	1 3/16
1	PFA4-16-FTF-61-1	4.57	1.71	2.56	0.88	1 3/4	1 5/8

穿板变径接头

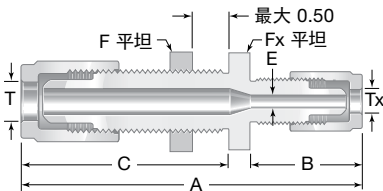

卡套管外径, in.		订购号	尺寸, in.					
T	Tx		A	B	C	E	F	Fx
3/8	1/4	PFA4-6-FTF-61-4-1	3.39	1.15	2.03	0.15	15/16	13/16
1/2	3/8	PFA4-8-FTF-61-6-1	3.61	1.25	2.13	0.25	1 1/16	15/16
3/4	1/2	PFA4-12-FTF-61-8-1	3.88	1.35	2.28	0.38	1 5/16	1 3/16
1	3/4	PFA4-16-FTF-61-12-1	4.29	1.50	2.56	0.63	1 3/4	1 5/8

外螺纹接头

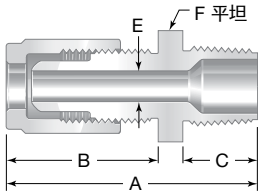

JIS (ISO/BSP 锥形) 端接

要订购 JIS (ISO/BSP 锥形) 端接, 请在订购号中插入 RT.

例如: PFA4-4-FTF-1-4RT-1

NPT

卡套管 外径 in.	NPT 尺寸 in.	订购号	尺寸, in.					
			A	B	C	E	F	
1/4	1/8	PFA4-4-FTF-1-2-1 ^①	1.99	1.15	0.45	0.15	5/8	
	1/4	PFA4-4-FTF-1-4-1	2.09		0.55		5/8	
	3/8	PFA4-4-FTF-1-6-1	2.09		0.55		11/16	
	1/2	PFA4-4-FTF-1-8-1	2.20		0.66		15/16	
	3/4	PFA4-4-FTF-1-12-1 ^①	2.21		0.67		1 3/16	
3/8	1/4	PFA4-6-FTF-1-4-1	2.09	1.25	0.55	0.25	13/16	
	3/8	PFA4-6-FTF-1-6-1	2.09		0.55		13/16	
	1/2	PFA4-6-FTF-1-8-1	2.21		0.66		15/16	
	3/4	PFA4-6-FTF-1-12-1 ^①	2.21		0.67		1 3/16	
1/2	1/4	PFA4-8-FTF-1-4-1	2.20	1.35	0.55	0.38	15/16	
	3/8	PFA4-8-FTF-1-6-1	2.20		0.55		15/16	
	1/2	PFA4-8-FTF-1-8-1	2.31		0.66		15/16	
	3/4	PFA4-8-FTF-1-12-1	2.32		0.67		1 3/16	
3/4	1/2	PFA4-12-FTF-1-8-1	2.45	1.50	0.66	0.55	1 3/16	
	3/4	PFA4-12-FTF-1-12-1	2.46		0.67		0.63	1 3/16
	1	PFA4-12-FTF-1-16-1	2.66		0.85		0.63	1 7/16
1	3/4	PFA4-16-FTF-1-12-1	2.67	1.71	0.67	0.66	1 7/16	
	1	PFA4-16-FTF-1-16-1	2.90		0.85		0.88	1 7/16

① 不提供 JIS (ISO/BSP 锥形) 端接。

穿板 NPT

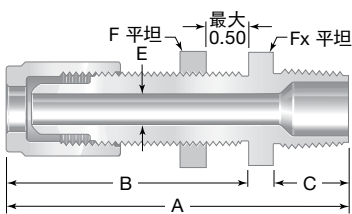

卡套管 外径 in.	NPT 尺寸 in.	订购号	尺寸, in.					
			A	B	C	E	F	Fx
1/4	1/4	PFA4-4-FTF-11-4-1	2.67	1.93	0.55	0.15	3/4	11/16
3/8	3/8	PFA4-6-FTF-11-6-1	2.79	2.03	0.55	0.25	5/16	3/16
1/2	1/2	PFA4-8-FTF-11-8-1	3.02	2.13	0.66	0.38	1 1/16	15/16
3/4	3/4	PFA4-12-FTF-11-12-1	3.20	2.28	0.67	0.63	1 5/16	1 3/16
1	1	PFA4-16-FTF-11-16-1	3.64	2.56	0.85	0.88	1 3/4	1 5/8

直通接头

内螺纹连接接头

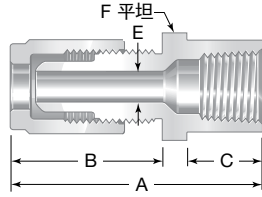

NPT

卡套管 外径 in.	NPT 尺寸 in.	订购号	尺寸, in.				
			A	B	C	E	F
1/4	1/8	PFA4-4-FTF-7-2-1	1.97	1.15	0.63	0.15	5/8
	1/4	PFA4-4-FTF-7-4-1	1.97				3/4
	3/8	PFA4-4-FTF-7-6-1	1.99				15/16
3/8	1/4	PFA4-6-FTF-7-4-1	2.07	1.25	0.63	0.25	3/4
	3/8	PFA4-6-FTF-7-6-1	2.09				15/16
	1/2	PFA4-6-FTF-7-8-1	2.11				1 1/8
1/2	3/8	PFA4-8-FTF-7-6-1	2.19	1.35	0.63	0.38	15/16
	1/2	PFA4-8-FTF-7-8-1	2.21				1 1/8
	3/4	PFA4-8-FTF-7-12-1	2.27				1 3/8
3/4	1/2	PFA4-12-FTF-7-8-1	2.36	1.50	0.63	0.63	1 1/8
	3/4	PFA4-12-FTF-7-12-1	2.42				1 3/8
1	1	PFA4-16-FTF-7-16-1	2.87	1.71	0.85	0.88	1 5/8

空间节省型变径接头

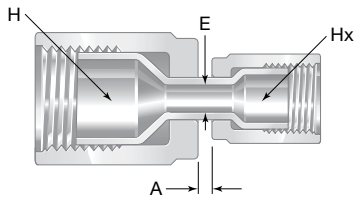

内螺纹扩口

扩口尺寸, in.		订购号	尺寸, in.	
H	Hx		A	E
3/8	1/4	PFA4-6-FTFX-6-4-1	0.45	0.15
	1/2		0.41	0.25
1/2	1/4	PFA4-8-FTFX-6-4-1	0.44	0.15
	3/8	PFA4-8-FTFX-6-6-1	0.43	0.25
	1/2	PFA4-12-FTFX-6-8-1	0.51	0.38
3/4	1/4	PFA4-12-FTFX-6-4-1	0.44	0.15
	3/8	PFA4-12-FTFX-6-6-1	0.43	0.25
	1/2	PFA4-12-FTFX-6-8-1	0.51	0.38
1	3/8	PFA4-16-FTFX-6-6-1	0.38	0.25
	1/2	PFA4-16-FTFX-6-8-1	0.45	0.38
	3/4	PFA4-16-FTFX-6-12-1	0.38	0.63

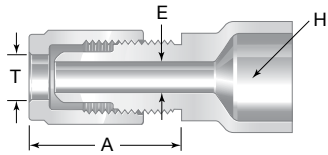

外螺纹到内螺纹扩口

扩口尺寸, in.		订购号	尺寸, in.	
H	T		A	E
3/8	1/4	PFA4-4-FTF-R-6X-1	1.21	0.15
	1/2		1.60	0.25
1/2	1/4	PFA4-4-FTF-R-8X-1	1.21	0.15
	3/8	PFA4-6-FTF-R-8X-1	1.33	0.25
	1/2	PFA4-8-FTF-R-12X-1	1.46	0.38
3/4	1/4	PFA4-4-FTF-R-12X-1	1.21	0.15
	3/8	PFA4-6-FTF-R-12X-1	1.33	0.25
	1/2	PFA4-8-FTF-R-12X-1	1.46	0.38
1	1/4	PFA4-4-FTF-R-16X-1	1.15	0.15
	3/8	PFA4-6-FTF-R-16X-1	1.27	0.25
	1/2	PFA4-8-FTF-R-16X-1	1.40	0.38
	3/4	PFA4-12-FTF-R-16X-1	1.57	0.63

端帽, 螺母和
堵塞

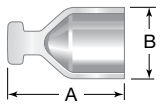

与一个螺母一起使用来堵塞外螺纹孔口。

扩口堵塞

扩口 尺寸 in.	订购号	尺寸, in.	
		A	B
1/4	PFA4-4-FTF-P-B	0.73	0.39
3/8	PFA4-6-FTF-P-B	0.86	0.53
1/2	PFA4-8-FTF-P-B	0.93	0.68
3/4	PFA4-12-FTF-P-B	1.08	0.93
1	PFA4-16-FTF-P-B	1.22	1.26

螺母

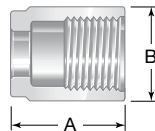

卡套管 外径 in.	订购号 ^①	尺寸, in.	
		A	B
1/4	PVDF-4-FTF-B	1.00	0.73
3/8	PVDF-6-FTF-B	1.01	0.85
1/2	PVDF-8-FTF-B	1.09	1.00
3/4	PVDF-12-FTF-B	1.25	1.32
1	PVDF-16-FTF-B	1.49	1.76

① 订购号中要求的是 PVDF 螺母。要订购 PFA 螺母, 请把订购号中的 PVDF 更换为 PFA4。

例如: PFA4-4-FTF-B

直通接头

端帽, 螺母和堵塞

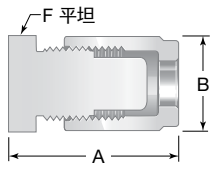

用来盖住卡套管。

扩口端帽和螺母

卡套管 外径 in.	订购号	尺寸, in.		
		A	B	F
1/4	PFA4-4-FTF-C-B-1	1.45	0.78	5/8
3/8	PFA4-6-FTF-C-B-1	1.52	0.91	13/16
1/2	PFA4-8-FTF-C-B-1	1.67	1.03	15/16
3/4	PFA4-12-FTF-C-B-1	1.82	1.35	1 3/16
1	PFA4-16-FTF-C-B-1	2.04	1.75	1 7/16

穿板螺母

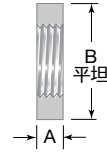

卡套管 外径 in.	订购号 ^①	尺寸, in.	
		A	B
1/4	PVDF-4-PMN-B	0.26	3/4
3/8	PVDF-6-PMN-B	0.26	15/16
1/2	PVDF-8-PMN-B	0.27	1 1/16
3/4	PVDF-12-PMN-B	0.28	1 5/16
1	PVDF-16-PMN-B	0.29	1 3/4

① 不提供 PFA 产品。

90° 弯头

联合接头

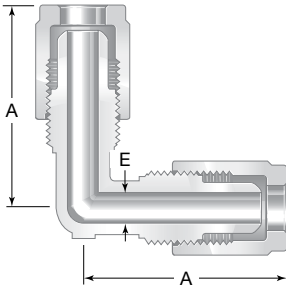

联合接头

卡套管 外径 in.	订购号	尺寸, in.	
		A	E
1/4	PFA4-4-FTF-9-1	1.61	0.15
3/8	PFA4-6-FTF-9-1	1.73	0.25
1/2	PFA4-8-FTF-9-1	1.83	0.38
3/4	PFA4-12-FTF-9-1	2.18	0.63
1	PFA4-16-FTF-9-1	2.70	0.87

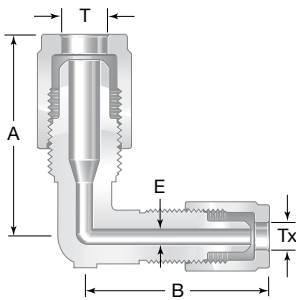

变径联合接头

卡套管外径, in.		订购号	尺寸, in.		
T	Tx		A	B	E
3/8	1/4	PFA4-6-FTF-9-4-1	1.73	1.61	0.15
1/2	1/4	PFA4-8-FTF-9-4-1	1.83	1.61	0.15
	3/8	PFA4-8-FTF-9-6-1		1.73	0.25
3/4	1/2	PFA4-12-FTF-9-8-1	2.18	1.83	0.38
1	1/2	PFA4-16-FTF-9-8-1	2.70	1.99	0.38
	3/4	PFA4-16-FTF-9-12-1		2.18	0.63

外螺纹

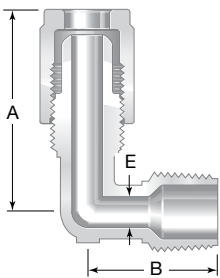

JIS (ISO/BSP 锥形) 端接

要订购 JIS (ISO/BSP 锥形) 端接, 请在订购号中插入 RT。

例如: PFA4-4-FTF-2-4RT-1

NPT

卡套管 外径 in.	NPT 尺寸 in.	订购号	尺寸, in.		
			A	B	E
1/4	1/8	PFA4-4-FTF-2-2-1 ^①	1.61	1.07	0.15
	1/4	PFA4-4-FTF-2-4-1			
	3/8	PFA4-4-FTF-2-6-1			
3/8	1/4	PFA4-6-FTF-2-4-1	1.73	1.07	0.25
	3/8	PFA4-6-FTF-2-6-1			
	1/2	PFA4-6-FTF-2-8-1			
1/2	1/4	PFA4-8-FTF-2-4-1	1.83	1.07	0.25
	3/8	PFA4-8-FTF-2-6-1			
	1/2	PFA4-8-FTF-2-8-1			
	3/4	PFA4-8-FTF-2-12-1			
3/4	1/2	PFA4-12-FTF-2-8-1	2.18	1.37	0.53
	3/4	PFA4-12-FTF-2-12-1			
	1	PFA4-12-FTF-2-16-1			
1	3/4	PFA4-16-FTF-2-12-1	2.70	1.64	0.66
	1	PFA4-16-FTF-2-16-1			

① 不提供 JIS (ISO/BSP 锥形) 端接。

90° 弯头

内螺纹螺母

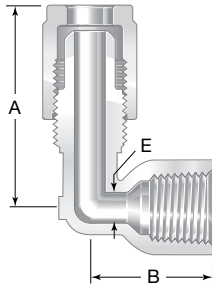

NPT

卡套管 外径 in.	NPT 尺寸 in.	订购号	尺寸, in.		
			A	B	E
1/4	1/8	PFA4-4-FTF-8-2-1	1.77	0.81	0.15
	1/4	PFA4-4-FTF-8-4-1		0.94	
	3/8	PFA4-4-FTF-8-6-1		1.00	
3/8	1/4	PFA4-6-FTF-8-4-1	1.89	0.94	0.25
	3/8	PFA4-6-FTF-8-6-1		1.00	
	1/2	PFA4-6-FTF-8-8-1		1.23	
1/2	1/4	PFA4-8-FTF-8-4-1	1.99	0.96	0.36
	3/8	PFA4-8-FTF-8-6-1		1.00	
	1/2	PFA4-8-FTF-8-8-1		1.23	

空间节省型弯头

联合接头

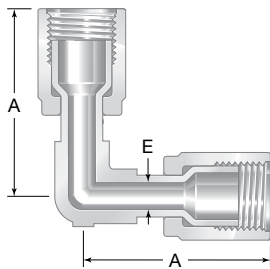

内螺纹扩口

扩口 尺寸 in.	订购号	尺寸, in.	
		A	E
1/4	PFA4-4-FTFX-9-1	1.64	0.15
3/8	PFA4-6-FTFX-9-1	1.73	0.25
1/2	PFA4-8-FTFX-9-1	1.94	0.38
3/4	PFA4-12-FTFX-9-1	2.26	0.63
1	PFA4-16-FTFX-9-1	2.77	0.88

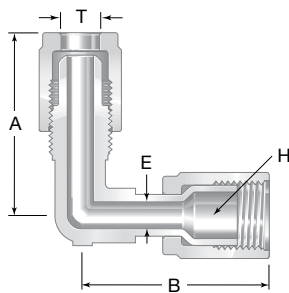

外螺纹到内螺纹扩口

T, 卡套 管外径 in.	H, 扩口 尺寸 in.	订购号	尺寸, in.		
			A	B	E
1/4	1/4	PFA4-4-FTF-9-4X-1	1.65	1.64	0.15
	3/8	PFA4-4-FTF-9-6X-1		1.73	
	1/2	PFA4-4-FTF-9-8X-1		1.84	
3/8	1/4	PFA4-6-FTF-9-4X-1	1.75	1.64	0.15
	3/8	PFA4-6-FTF-9-6X-1		1.73	
	1/2	PFA4-6-FTF-9-8X-1		1.84	
1/2	3/8	PFA4-8-FTF-9-6X-1	1.86	1.73	0.38
	1/2	PFA4-8-FTF-9-8X-1		1.83	
	3/4	PFA4-8-FTF-9-12X-1		2.26	
	1	PFA4-8-FTF-9-16X-1		2.02	
3/4	1/2	PFA4-12-FTF-9-8X-1	2.18	1.84	0.38
	3/4	PFA4-12-FTF-9-12X-1		2.26	
	1	PFA4-12-FTF-9-16X-1		2.77	
1	3/4	PFA4-16-FTF-9-12X-1	2.70	2.26	0.63
	1	PFA4-16-FTF-9-16X-1		2.77	

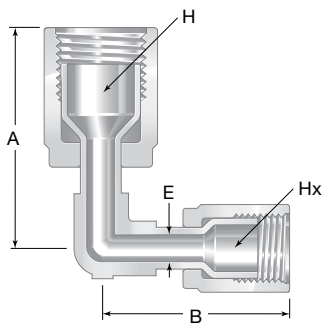

变径内螺纹扩口

扩口尺寸 in.		订购号	尺寸, in.		
H	Hx		A	B	E
3/8	1/4	PFA4-6-FTFX-9-4-1	1.73	1.64	0.15
1/2	3/8	PFA4-8-FTFX-9-6-1	1.84	1.73	0.25
3/4	1/2	PFA4-12-FTFX-9-8-1	2.26	1.84	0.38
1	3/4	PFA4-16-FTFX-9-12-1	2.77	2.26	0.63

空间节省型弯头

联合接头

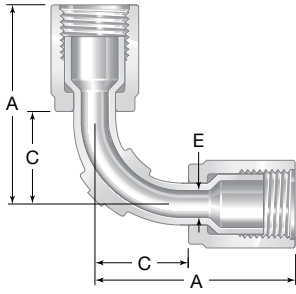

内螺纹扩口

扩口尺寸 in.	订购号	尺寸, in.		
		A	C	E
1/4	PFA4-4-FTFX-9S-1	1.95	0.95	0.15
3/8	PFA4-6-FTFX-9S-1	2.00	0.98	0.25
1/2	PFA4-8-FTFX-9S-1	2.08	0.99	0.38
3/4	PFA4-12-FTFX-9S-1	2.65	1.40	0.63
1	PFA4-16-FTFX-9S-1	3.21	1.72	0.88

外螺纹到内螺纹扩口

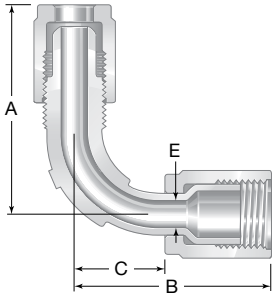

卡套管外径/ 扩口尺寸 in.	订购号	尺寸, in.			
		A	B	C	E
1/4	PFA4-4-FTF-9S-4X-1	2.15	1.95	0.95	0.15
3/8	PFA4-6-FTF-9S-6X-1	2.25	2.00	0.98	0.25
1/2	PFA4-8-FTF-9S-8X-1	2.35	2.08	0.99	0.38
3/4	PFA4-12-FTF-9S-12X-1	2.75	2.65	1.40	0.63
1	PFA4-16-FTF-9S-16X-1	3.28	3.21	1.72	0.88

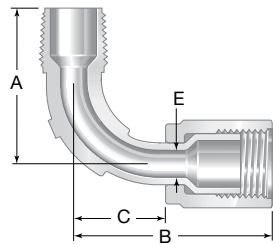

外螺纹 NPT

NPT 尺寸/ 扩口尺寸 in.	订购号	尺寸, in.			
		A	B	C	E
1/4	PFA4-4-FTFX-2S-4-1	1.30	1.95	0.95	0.15
3/8	PFA4-6-FTFX-2S-6-1	1.55	2.00	0.98	0.25
1/2	PFA4-8-FTFX-2S-8-1	1.66	2.08	0.99	0.38
3/4	PFA4-12-FTFX-2S-12-1	1.92	2.65	1.40	0.63
1	PFA4-16-FTFX-2S-16-1	2.60	3.21	1.72	0.88

三通接头

联合接头

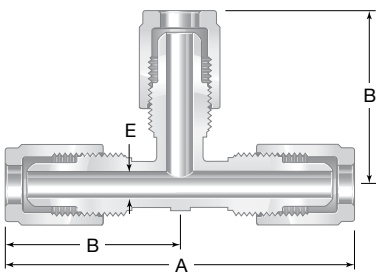

联合接头

卡套管 外径 in.	订购号	尺寸, in.		
		A	B	E
1/4	PFA4-4-FTF-3-1	3.28	1.61	0.15
3/8	PFA4-6-FTF-3-1	3.48	1.73	0.25
1/2	PFA4-8-FTF-3-1	3.68	1.83	0.38
3/4	PFA4-12-FTF-3-1	4.36	2.18	0.63
1	PFA4-16-FTF-3-1	5.40	2.70	0.88

三通接头

联合接头

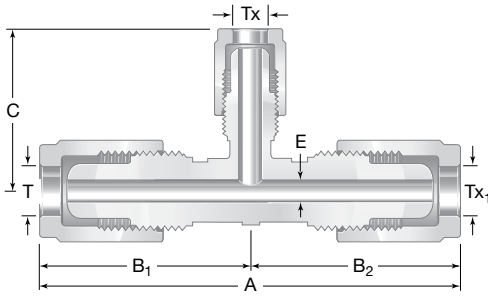

变径联合接头

卡套管外径, in.			订购号	尺寸, in.				
T	Tx	Tx ₁		A	B ₁	B ₂	C	E
3/8	1/4	1/4	PFA4-6-FTF-3-4-4-1	3.40	1.75	1.65	1.65	0.15
	1/4	3/8	PFA4-6-FTF-3-6-4-1			1.75	1.65	
	3/8	1/4	PFA4-6-FTF-3-4-6-1			1.65	1.75	
1/2	1/4	1/4	PFA4-8-FTF-3-4-4-1	3.51	1.86	1.65	1.65	0.15
	1/4	1/2	PFA4-8-FTF-3-8-4-1			1.86	1.65	
	3/8	3/8	PFA4-8-FTF-3-6-6-1			1.75	1.75	
	3/8	1/2	PFA4-8-FTF-3-8-6-1			1.86	1.75	
	1/2	3/8	PFA4-8-FTF-3-6-8-1			1.75	1.86	
3/4	1/4	3/4	PFA4-12-FTF-3-12-4-1	4.36	2.18	2.18	1.65	0.15
	3/8	3/4	PFA4-12-FTF-3-12-6-1			2.18	1.75	
	1/2	3/4	PFA4-12-FTF-3-12-8-1			2.18	1.86	
	3/4	1/2	PFA4-12-FTF-3-8-12-1			1.86	2.18	
1	3/4	1	PFA4-16-FTF-3-16-12-1	5.40	2.70	2.70	2.18	0.63

外螺纹

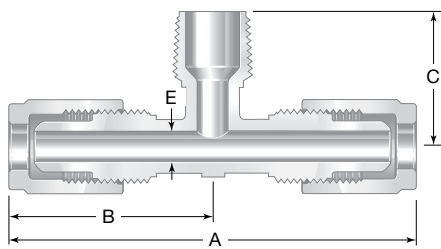

支管, NPT

卡套管 外径 in.	NPT 尺寸 in.	订购号	尺寸, in.			
			A	B	C	E
1/4	1/8	PFA4-4-FTF-3-2TTM-1	3.22	1.61	1.07	0.15
	1/4	PFA4-4-FTF-3-4TTM-1				
3/8	1/4	PFA4-6-FTF-3-4TTM-1	3.46	1.73	1.07	0.25
	3/8	PFA4-6-FTF-3-6TTM-1				
1/2	3/8	PFA4-8-FTF-3-6TTM-1	3.66	1.83	1.07	0.38
	1/2	PFA4-8-FTF-3-8TTM-1				
3/4	1/4	PFA4-12-FTF-3-4TTM-1	4.36	2.18	1.27	0.25
	3/4	PFA4-12-FTF-3-12TTM-1				
1	1/4	PFA4-16-FTF-3-4TTM-1	5.40	2.70	1.56	0.25
	1	PFA4-16-FTF-3-16TTM-1				

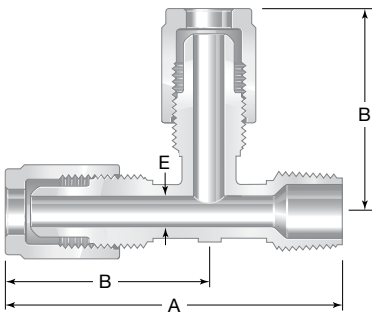

直通, NPT

卡套管 外径 in.	NPT 尺寸 in.	订购号	尺寸, in.		
			A	B	E
1/4	1/8	PFA4-4-FTF-3-2TMT-1	2.68	1.61	0.15
	1/4	PFA4-4-FTF-3-4TMT-1			
3/8	3/8	PFA4-6-FTF-3-6TMT-1	2.80	1.73	0.25
1/2	1/2	PFA4-8-FTF-3-8TMT-1	3.01	1.83	0.38
3/4	3/4	PFA4-12-FTF-3-12TMT-1	3.55	2.18	0.63
1	1	PFA4-16-FTF-3-16TMT-1	4.50	2.70	0.88

空间节省型三通

联合接头

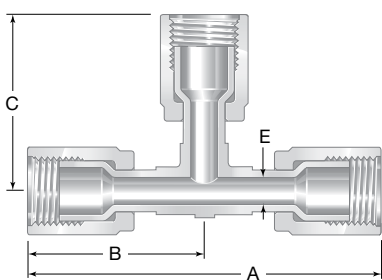

联合接头

卡套管 外径 in.	订购号	尺寸, in.			
		A	B	C	E
1/4	PFA4-4-FTFX-3-1	3.28	1.64	1.64	0.15
3/8	PFA4-6-FTFX-3-1	3.46	1.73	1.73	0.25
1/2	PFA4-8-FTFX-3-1	3.68	1.84	1.86	0.38
3/4	PFA4-12-FTFX-3-1	4.52	2.26	2.26	0.63
1	PFA4-16-FTFX-3-1	5.54	2.77	2.77	0.88

空间节省型三通

联合接头

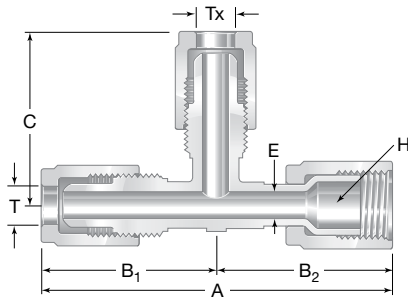

直通

卡套管外径, in.		H, 扩口尺寸 in.	订购号	尺寸, in.				
T	Tx			A	B ₁	B ₂	C	E
1/4	1/4	1/4	PFA4-4-FTF-3-4TXT-1	3.29	1.65	1.64	1.65	0.15
3/8	3/8	3/8	PFA4-6-FTF-3-6TXT-1	3.48	1.75	1.73	1.75	0.25
1/2	1/2	1/2	PFA4-8-FTF-3-8TXT-1	3.70	1.86	1.84	1.86	0.38
3/4	3/8	3/4	PFA4-12-FTF-3-12-6TXT-1	4.44	2.18	2.26	1.73	0.25
	1/2		PFA4-12-FTF-3-12-8TXT-1				1.86	0.38
	3/4		PFA4-12-FTF-3-12TXT-1				2.18	0.63
1	1	1	PFA4-16-FTF-3-16TXT-1	5.47	2.70	2.77	2.70	0.88

直通, 直通

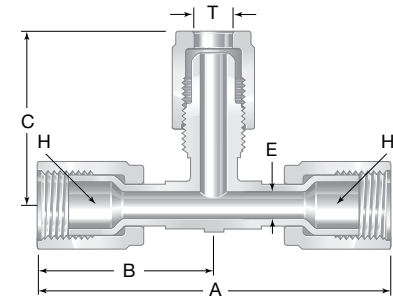

H, 扩口尺寸 in.	T, 卡套管外径 in.	订购号	尺寸, in.				
			A	B	C	E	
1/4	1/4	PFA4-4-FTFX-3-4XXT-1	3.28	1.64	1.65	0.15	
3/8	3/8	PFA4-6-FTFX-3-6XXT-1	3.46	1.73	1.75	0.25	
1/2	1/2	PFA4-8-FTFX-3-8XXT-1	3.68	1.84	1.86	0.38	
3/4	3/8	PFA4-12-FTFX-3-12-6XXT-1	4.52	2.26	1.86	1.75	0.25
	1/2	PFA4-12-FTFX-3-12-8XXT-1				1.86	0.38
	3/4	PFA4-12-FTFX-3-12XXT-1				2.18	0.63

支管

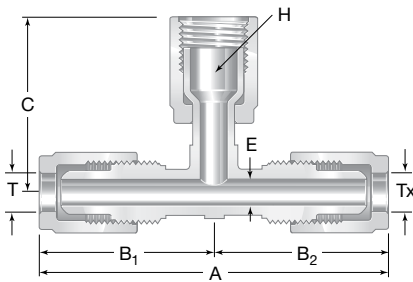

卡套管外径, in.		H, 扩口尺寸 in.	订购号	尺寸, in.				
T	Tx			A	B ₁	B ₂	C	E
1/4	1/4	1/4	PFA4-4-FTF-3-4TTX-1	3.30	1.65	1.65	1.64	0.15
3/8	3/8	1/4	PFA4-6-FTF-3-4TTX-1	3.50	1.75	1.75	1.64	0.15
		3/8	PFA4-6-FTF-3-6TTX-1				1.73	0.25
1/2	1/2	3/8	PFA4-8-FTF-3-6TTX-1	3.72	1.86	1.86	1.73	0.25
		1/2	PFA4-8-FTF-3-8TTX-1				1.84	0.38
3/4	3/4	1/4	PFA4-12-FTF-3-4TTX-1	4.36	2.18	2.18	1.64	0.15
	1/2	PFA4-12-FTF-3-8-12TTX-1	4.04				1.86	2.26
1	1	3/4	PFA4-16-FTF-3-12TTX-1	5.40	2.70	2.70	2.26	0.63
		1	PFA4-16-FTF-3-16TTX-1				2.77	0.88

支管, 直通

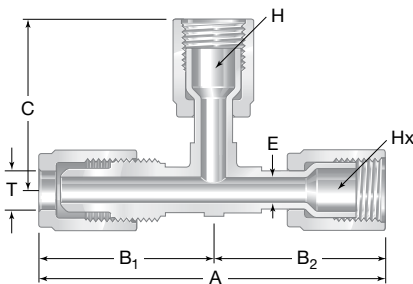

T, 卡套管外径 in.	扩口尺寸, in.		订购号	尺寸, in.							
	H	Hx		A	B ₁	B ₂	C	E			
1/4	1/4	1/4	PFA4-4-FTFX-3-4TXX-1	3.29	1.65	1.64	1.64	0.15			
3/8	1/4	3/8	PFA4-6-FTFX-3-6-4TXX-1	3.48	1.75	1.73	1.64	0.15			
	3/8		PFA4-6-FTFX-3-6TXX-1				1.73	0.25			
1/2	1/2	1/2	PFA4-8-FTFX-3-8TXX-1	3.70	1.86	1.84	1.84	0.38			
3/4	1/2	3/4	PFA4-12-FTFX-3-12-8TXX-1	4.44	2.18	2.26	1.84	0.38			
	3/4	1/2	PFA4-12-FTFX-3-8-12TXX-1				4.09	2.26	1.83	2.26	0.38
	3/4	3/4	PFA4-12-FTFX-3-12TXX-1				4.44	2.18	2.26	2.26	0.63

卡箍管接头

PVDF 多重扩口接头

卡套管接头

孔口配置 (端视图)

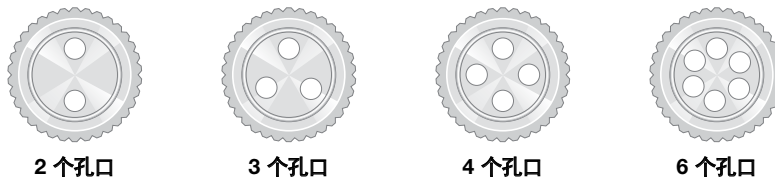

2 个孔口

3 个孔口

4 个孔口

6 个孔口

穿板接头

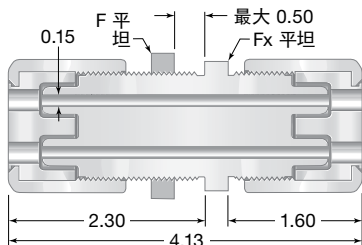

卡套管 外径 in.	孔口①	订购号	尺寸, in.		
			F	Fx	要求的孔 尺寸
1/4	2	PVDF-4-FTFM2-61-1	1 3/8	1 1/4	1 1/8
	3	PVDF-4-FTFM3-61-1	1 3/8	1 1/4	1 1/8
	4	PVDF-4-FTFM4-61-1	1 1/2	1 3/8	1 1/4
	6	PVDF-4-FTFM6-61-1	1 3/4	1 5/8	1 1/2

① 参阅孔口配置。

外螺纹 NPT

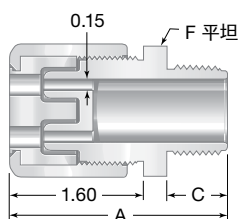

卡套管 外径 in.	NPT 尺寸 in.	孔口①	订购号	尺寸, in.		
				A	C	F
1/4	1/2	2	PVDF-4-FTFM2-1-8-1	2.49	0.66	1 1/4
		3	PVDF-4-FTFM3-1-8-1			
	3/4	2	PVDF-4-FTFM2-1-12-1	2.50	0.67	1 1/4
		3	PVDF-4-FTFM3-1-12-1			1 1/4
		4	PVDF-4-FTFM4-1-12-1			1 3/8
	1	3	PVDF-4-FTFM3-1-16-1	2.68	0.85	1 1/4
4		PVDF-4-FTFM4-1-16-1	2.68	0.85	1 3/8	
	6	PVDF-4-FTFM6-1-16-1	2.68	0.85	1 3/8	

① 参阅孔口配置。

过渡接头

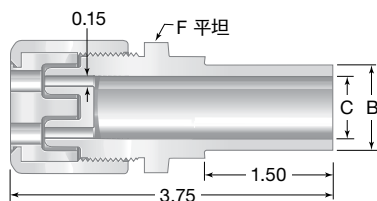

卡套管 外径 in.	孔口①	订购号	尺寸, in.		
			B	C	F
1/4	2	PVDF-4-FTFM2-R-20M-1	0.79	0.64	1 1/4
	3	PVDF-4-FTFM3-R-20M-1			
	2	PVDF-4-FTFM2-R-25M-1	0.98	0.82	1 1/4
	3	PVDF-4-FTFM3-R-25M-1			1 1/4
	4	PVDF-4-FTFM4-R-25M-1			1 3/8
	1/2	3	PVDF-4-FTFM3-R-32M-1	1.26	1.07
4		PVDF-4-FTFM4-R-32M-1	1 3/8		
6		PVDF-4-FTFM6-R-32M-1	1 5/8		

① 参阅孔口配置。

PVDF 过渡接头

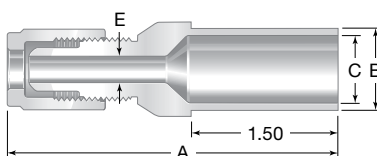

卡套管 外径 in.	订购号	尺寸, in.			
		A	B	C	E
1/4	PVDF-4-FTF-R-20M-1	3.30	0.79	0.64	0.15
	PVDF-4-FTF-R-25M-1		0.98	0.82	
3/8	PVDF-6-FTF-R-20M-1	3.40	0.79	0.64	0.25
	PVDF-6-FTF-R-25M-1		0.98	0.82	
1/2	PVDF-8-FTF-R-20M-1	3.50	0.79	0.64	0.38
	PVDF-8-FTF-R-25M-1		0.98	0.82	
	PVDF-8-FTF-R-32M-1		1.26	1.07	
	PVDF-8-FTF-R-40M-1		1.57	1.38	
3/4	PVDF-12-FTF-R-20M-1	3.64	0.79	0.64	0.63
	PVDF-12-FTF-R-25M-1		0.98	0.82	
	PVDF-12-FTF-R-32M-1		1.26	1.07	
	PVDF-12-FTF-R-40M-1		1.57	1.38	
1	PVDF-16-FTF-R-25M-1	3.80	0.98	0.82	0.87
	PVDF-16-FTF-R-32M-1		1.26	1.07	
	PVDF-16-FTF-R-40M-1		1.57	1.38	

双重防泄漏接头

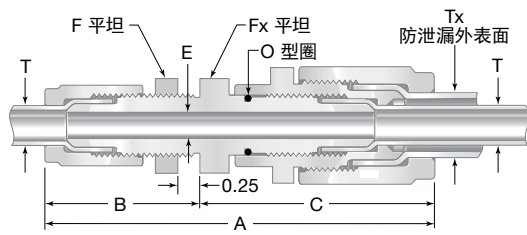

图中画出了卡套管。O 型圈为 Aflas®。

卡套管外径, in.		订购号	尺寸, in.					
T	Tx		A	B	C	E	F	Fx
1/4	1/2	PFA4-4-FTF-6-DC8-1	3.60	1.53	2.07	0.15	3/4	11/16
3/8	3/4	PFA4-6-FTF-6-DC12-1	3.95	1.63	2.32	0.25	1 5/16	13/16
1/2	3/4	PFA4-8-FTF-6-DC12-1	4.15	1.73	2.42	0.38	1 1/16	15/16
3/4	1	PFA4-12-FTF-6-DC16-1	4.58	1.88	2.70	0.63	1 5/16	1 3/16

世伟洛克超高纯含氟聚合物产品

世伟洛克的超高纯含氟聚合物产品包括气动和四分之一圈手动径向隔膜密封截止阀，无 O 型圈单向阀，细牙螺纹扩口接头和卡套管。

欲了解更多信息，请参阅如下世伟洛克产品目录：

- 超高纯含氟聚合物隔膜阀 — DRP 系列 (MS-02-171C4), P 558
- 超高纯含氟聚合物无 O 型圈提升阀芯单向阀 — CHP 系列, MS-02-320
- 超高纯含氟聚合物卡套管, MS-02-196

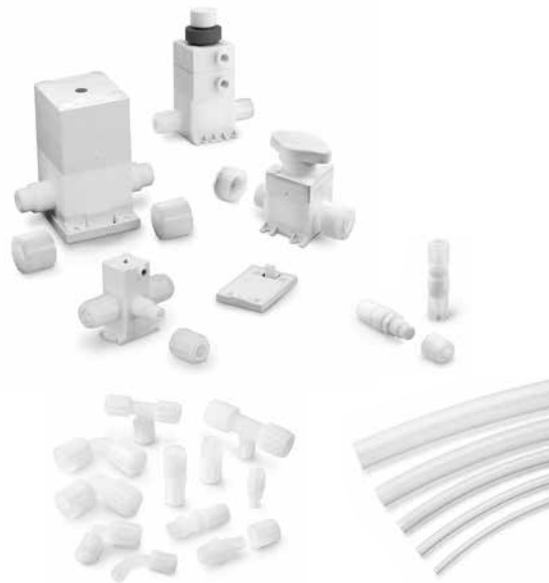

安全产品选型

选择产品时，必须考虑总体系统设计以保证获得安全的、无故障的产品性能。产品的功能、材料兼容性、充足的额定值、正确的安装、使用和维护是系统设计者和用户的责任。

质量保证信息

世伟洛克公司对其产品提供终身有限保证。如需了解详情，请访问公司网站 swagelok.com.cn 或联系世伟洛克授权代表。

简介

自 1947 年以来，世伟洛克已设计、开发和制造了高品质通用和专用流体系统产品来满足全球行业不断变化的需求。我们注重了解客户的需求，及时找到解决方案，并以我们的产品和服务来增加价值。

我们十分高兴地提供这一纸质形式的 *世伟洛克产品目录*，该目录列出了超过 100 个单独的产品目录、技术公告和参考文件，并将它们编制成方便易用的卷册。每个产品目录在印刷时都是新版本，其修订号显示在产品目录的最后一页。后续修订版将取代印刷版，并将公布于世伟洛克网站和世伟洛克电子目录（eDTR）当中。

欲了解更多信息，请访问世伟洛克网站，或联系您当地的世伟洛克授权销售和服务代表。

质量保证信息

世伟洛克公司对其产品提供终身有限保证。如需了解详情，请访问公司网站 swagelok.com.cn 或联系世伟洛克授权代表。

并非以下列出的所有商标均适用于此目录。
Swagelok, Cajon, Ferrule-Pak, Goop, Hinging-Collecting, IGC, Kenmac, Micro-Fit, Nupro, Snoop, Sno-Trik, SWAK, VCO, VCR, Ultra-Torr, Whitey—TM Swagelok Company
15-7 PH—TM AK Steel Corp.
AccuTrak, Beacon, Westlock—TM Tyco International Services
Aflas—TM Asahi Glass Co., Ltd.
ASCO, El-O-Matic—TM Emerson
AutoCAD—TM Autodesk, Inc.
CSA—TM Canadian Standards Association
Crastin, DuPont, Kalrez, Krytox, Teflon, Viton—TM E.I. duPont Nemours and Company
DeviceNet—TM ODVA
Dyneon, Elgiloy, TFM—TM Dyneon
Elgiloy—TM Elgiloy Specialty Metals
FM—TM FM Global
Grafoil—TM GrafTech International Holdings, Inc.
Honeywell, MICRO SWITCH—TM Honeywell
MAC—TM MAC Valves
Microsoft, Windows—TM Microsoft Corp.
NACE—TM NACE International
PH 15-7 Mo, 17-7 PH—TM AK Steel Corp
picofast—Hans Turck KG
Pillar—TM Nippon Pillar Packing Company, Ltd.
Raychem—TM Tyco Electronics Corp.
Sandvik, SAF 2507—TM Sandvik AB
Simriz—TM Freudenberg-NOK
SolidWorks—TM SolidWorks Corporation
UL—Underwriters Laboratories Inc.
Xylan—TM Whitford Corporation
© 2020 Swagelok Company

安全产品选型

选择产品时，必须考虑总体系统设计以保证获得安全的、无故障的产品性能。产品的功能、材料兼容性、充足的额定值、正确的安装、使用和维护是系统设计者和用户的责任。

警告

请勿将世伟洛克产品或不符合工业设计标准的元件（包括世伟洛克卡套管接头端接）与其他制造商的产品或元件混用/互换。