



July 2nd, 2019

Dear Joanna Karpinski

Re: Reciprocal CRN Registration in Manitoba

Your application indicates that a CRN has been received in another Canadian Jurisdiction, and therefore your CRN has been registered in Manitoba as follows:

File Number: 39836
CRN: 0C21140.54
Scope: See Scope of Registration, Attachment A & B
Manufacturer: SWAGELOK

Please find attached invoice for registration.

As indicated by the Regulatory Reconciliation and Cooperation Table and the Reconciliation Agreement for the Canadian Registration Number (CRN) for Pressure Equipment, a CRN issued in any Canadian Jurisdiction will be accepted for use in Manitoba.

In accordance with Steam and Pressure Plants Regulation and CSA B51, it is the manufacturer's responsibility to file a Manufacturers Data Report, including partial data reports, with our office, prior to shipping pressure equipment to Manitoba.

Please contact me directly via email at Cheryl.Lashek@gov.mb.ca for any questions or concerns.

Cheryl Lashek, P.Eng
Director, ITSM
Inspection and Technical Services
Office of the Fire Commissioner
508 - 401 York Avenue, Winnipeg Manitoba R3C 0P8
T (204) 945-3507 | F (204) 948-2309



Technical Standards and Safety Authority
 345 Carlingview Drive
 Toronto, Ontario M9W 6N9
 www.tssa.org

Show facsimile of manufacturer's logo or trademark, as it will appear on the fitting, in the space below

Swagelok

STATUTORY DECLARATION Registration of Fittings

I, Joel Feldman, Vice President of Engineering
(Name and Position, e.g. President, Plant Manager, Chief Engineer)

of Swagelok Company
(Name of Manufacturer)

Located at 29500 Solon Road, Solon, Ohio 44139 USA (440) 248-4600 (440) 349-5970
(Plant Address) (Telephone No.) (Fax No.)

do solemnly declare that the fittings listed hereunder, which are subject to the **Technical Standards and Safety Act**, Boilers and Pressure Vessels Regulation, comply with all of the requirements of ASME B31.1 for unlisted components, and ASME B31.3 for unlisted components
(Title of recognized North American Standard)
 which specifies the dimensions, materials of construction, pressure/temperature ratings, identification marking the fittings and service;

or are not covered by the provisions of a recognized North American standard and are therefore manufactured to comply with _____ as supported by the attached data which identifies the dimensions, material of construction, pressure/temperature ratings and the basis for such ratings, the marking of the fitting for identification and service.

I further declare that the manufacture of these fittings is controlled by a quality system meeting the requirements of ISO 9001:2015 which has been verified by the following authority, BSI

The items covered by this declaration, for which I seek registration, are category C. Valves type fittings. In support of this application, the following information and/or test data are attached as follows:
ISO 9001:2015 Certificate, Attachment A, Attachment B, Catalog Information and other Support Documents
(drawings, calculations, test reports, etc.)

Declared before me at Solon in the State of Ohio
 the 07th day of December AD 2018.

Commissioner for Oaths:
Jamie L Ristan Jamie L Ristan
(Printed name) Resident Portage County
 Notary Public, State of Ohio
Jamie L Ristan My Commission Expires: 03/06/2019
(Signature)

Joel C. Feldman
(Signature of Declarer)

FOR OFFICE USE ONLY

To the best of my knowledge and belief, the application meets the requirements of the **Technical Standards and Safety Act**, Boilers and Pressure Vessels Regulation, and CSA Standard B51 and is accepted for registration in Category C.

Technical Standards and Safety Authority
Boilers and Pressure Vessels Safety Program

REGISTERED

CRN: OC 21140.5

C.R.N.: OC 21140.5

Registered by: [Signature]

Signed: [Signature]

Dated: Feb. 22, 2019

Date: Feb 22, 2019

NOTE: This registration expires on: Feb 22, 2029

**Information provided in this application is releasable under the Freedom of Information and Privacy Protection Act and may be disclosed upon request. For scope of registration see attached stamped documents [Signature]*

Attachment B: Scope of CRN Registration for Swagelok U Series Bellows-Sealed Valves (Category C)

This document represents the scope of Swagelok's U Series Bellows-Sealed Valves covered by this submission for CRN approval. These valves were designed and evaluated in accordance with ASME B31.1:2016 for unlisted components and B31.3:2016 for unlisted components.

Table 1 – Summary Table

Product Description or Series	Main Pressure Bearing Component	Main Pressure Bearing Material (Standard)	Port Connections and Sizes	Maximum Rated Pressure			Design Code of Construction
				At 100°F	Maximum Temperature		
				UG & UW	UG ¹	UW ²	
4U	Body, Bonnet, Bonnet nut	316 SS (ASTM A479)	Tube Fitting 1/4", 6mm Tube Socket Weld 1/4" Butt Weld 3/8"	2500 psig	2500 psig @ 650°F	250 psig @ 1200°F	ASME B31.1 (Unlisted Components) and ASME B31.3 (Unlisted Components)
			Female VCR 1/4"	2500 psig	2500 psig @ 650°F	480 psig @ 1000°F	
6U	Body, Bonnet, Bonnet nut	316 SS (ASTM A479)	Tube Fitting 3/8", 10mm Tube Socket Weld 3/8" Butt Weld 1/2"	2500 psig	2500 psig @ 650°F	250 psig @ 1200°F	
			Female VCR 1/2"	2500 psig	2500 psig @ 650°F	480 psig @ 1000°F	
8U	Body, Bonnet, Bonnet nut	316 SS (ASTM A479)	Tube Fitting 1/2", 12mm Tube Socket Weld 1/2" Butt Weld 3/4"	2500 psig	2500 psig @ 650°F	250 psig @ 1200°F	
			Female VCR 1/2"	2500 psig	2500 psig @ 650°F	480 psig @ 1000°F	
12U	Body, Bonnet, Bonnet nut	316 SS (ASTM A479)	Tube Socket Weld 3/4" Pipe Butt Weld 3/4" Tube Butt Weld 1"	2500 psig	2500 psig @ 650°F	250 psig @ 1200°F	

¹ – U-Series with a gasket bonnet seal

² – U-Series with a welded bonnet seal



Figure 1 – Pressure Retaining Components (typical 4U, 6U, or 8U hand operated valve)

Although the 12U Series Valve has a different internal design, all U Series Valves have the same configuration for pressure retaining components as shown below. The pressure retaining shell is made up of the body, the bonnet nut, and the bonnet as noted.

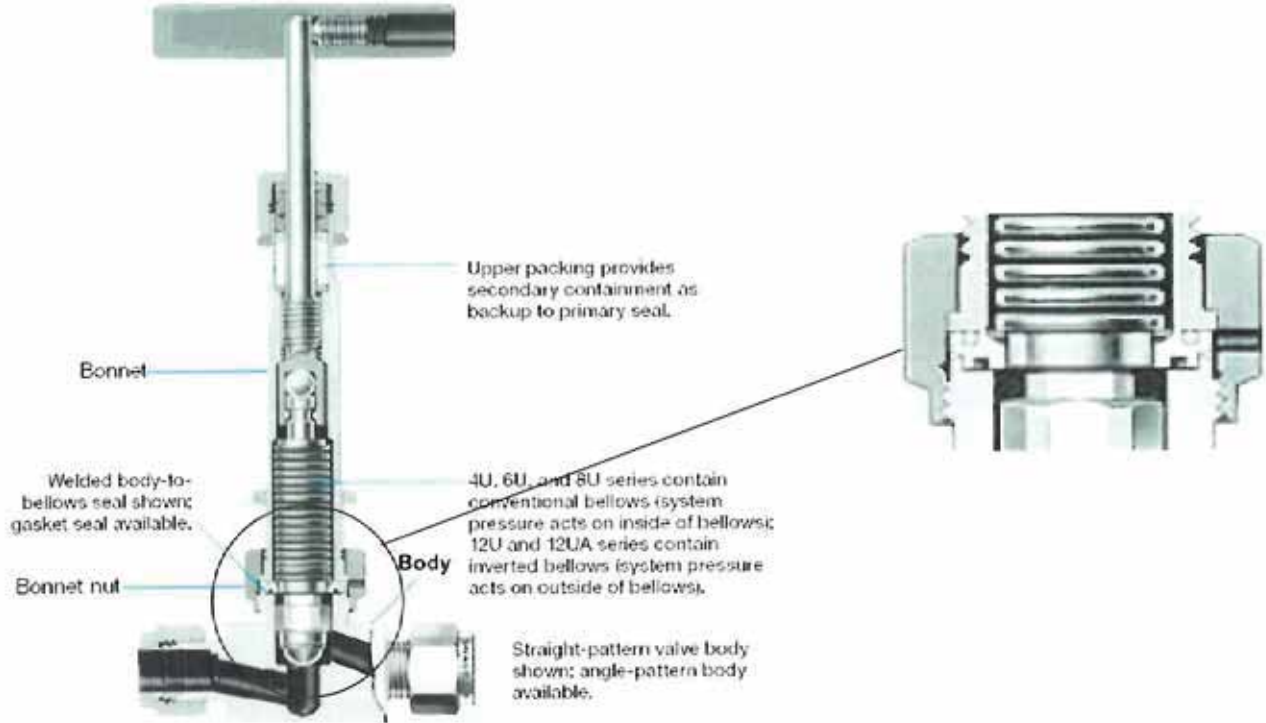

Bellows-Sealed, U Series Valve Configurations

Figure 1 – 4U, 6U, and 8U Series Valves

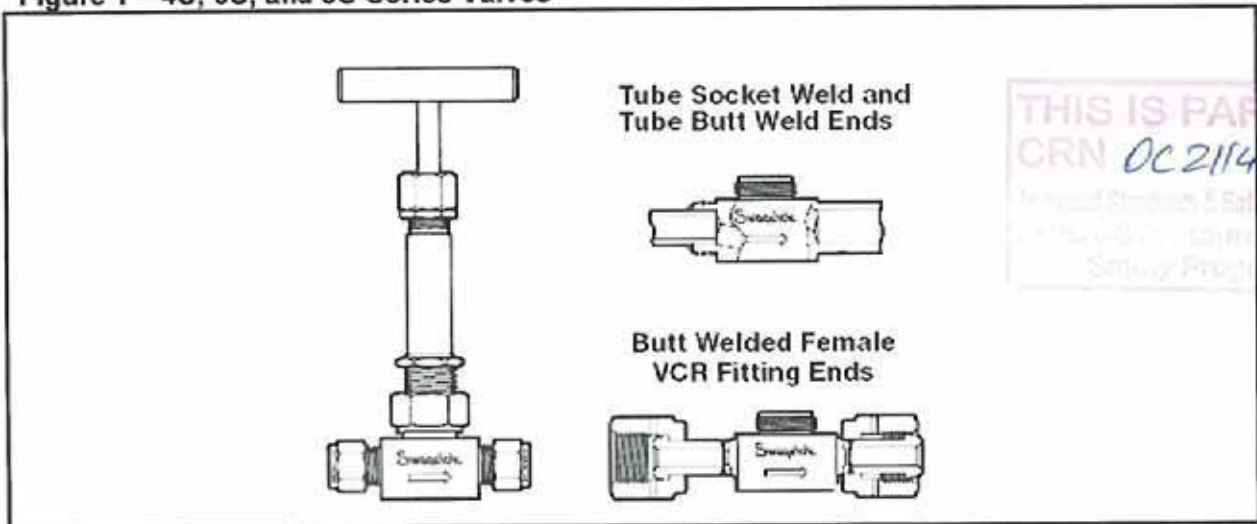

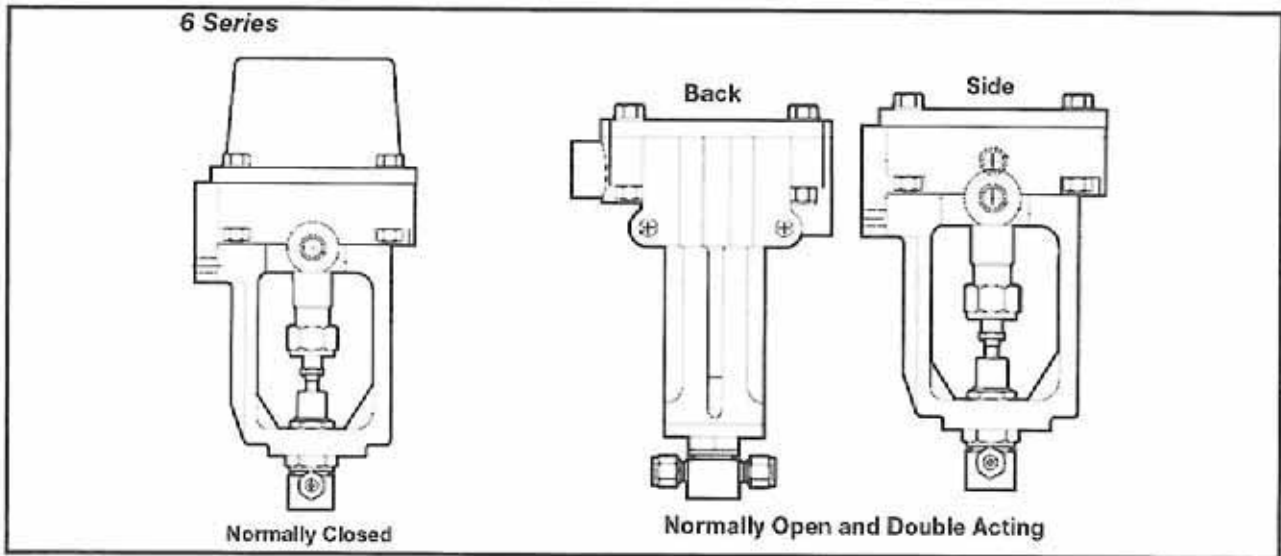
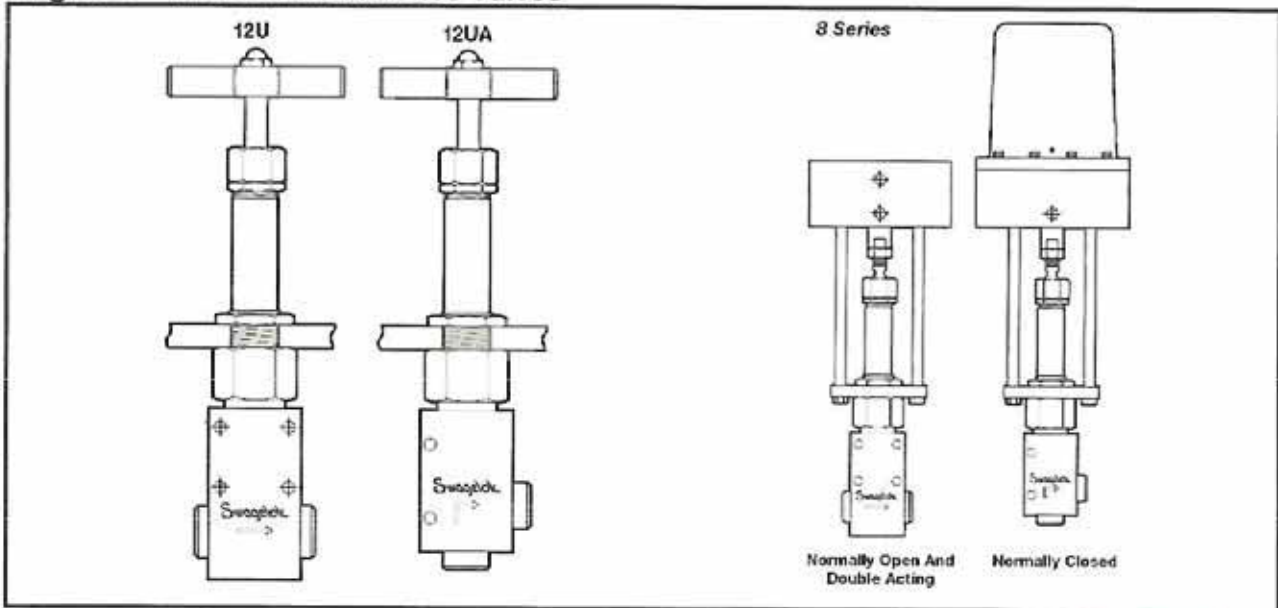

Figure 2 – 12U and 12UA Series Valves



THIS IS PART OF
CRN 0C21140.5
Technical Standards & Safety Authority
Bellows & Pressure Vessels

Product Options:

The U Series valve stem tips and gaskets listed below affect pressure and/or temperature ratings shown in the above Summary Table, but in all cases the ratings are less than those shown below:

Stem Tips

- 316 SS (regulating)
- Cobalt-based alloy (spherical)
- PCTFE/D1430 (cylindrical)
- Polyimide (conical)

Gaskets

- PTFE-coated 316 SS
- Silver-plated 316 SS

Additional options and non-pressure boundary alterations that do not affect pressure-temperature ratings may be made available within the scope of this registration. Examples of these would include, but not be limited to, handle options, indicator switches, actuators, etc.

Quality System

The Swagelok Company quality system complies with the requirements of ISO 9001:2015. The Swagelok Company maintains British Standards Institution Certificate of Registration Number FM 01729, which applies to all locations listed on the Certificate. The Sealed-Bellows, U Series Valves are made at a Swagelok Company location in Solon, Ohio.

References

The product catalog does not represent the full scope of the registration but rather details some of the most common options.

- Bellows-Sealed Valves, U Series Catalog – MS-01-38 Rev J

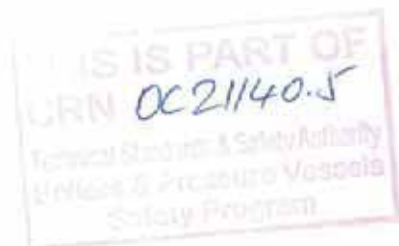

Attachment A. Swagelok Manufacturing Locations

This document lists the Swagelok locations where end item or component level manufacturing activities take place.

Swagelok Company 29500 Solon Road Solon, Ohio 44139 USA	Swagelok Company (Falon 1) 348 Bishop Road Highland Heights, Ohio 44143 USA
Swagelok Company (Highland) 318 Bishop Road Highland Heights, Ohio 44143 USA	Swagelok Company (Falon 2) 358 Bishop Road Highland Heights, Ohio 44143 USA
Swagelok Company (OFC) 29495 F.A. Lennon Drive Solon, Ohio 44139 USA	Swagelok Company (HPF) 6050 Cochran Road Solon, Ohio 44139 USA
Swagelok Company (Atlantic) 26651 Curtiss Wright Parkway Willoughby Hills, Ohio 44092 USA	Swagelok Company (Snow Metal) 6060 Cochran Road Solon, Ohio 44139 USA
Swagelok Company (Micro) 26653 Curtiss Wright Parkway Willoughby Hills, Ohio 44092 USA	Swagelok Company (Alfred) 29500 Ambina Drive Solon, Ohio 44139
Swagelok Hose Services Company (SHSC) 29900 Solon Industrial Parkway Solon, Ohio 44139	Swagelok Company (Strongsville) 15400 Foltz Road Strongsville, Ohio 44119
Swagelok (China) Fluid System Technologies Ltd. Changshu Export Process Zone Changshu Economic Development Zone Changshu, Jiangshu 215513 China	Swagelok Limited Ballafletcher Road Tromode IM4 4RA Isle of Man

THIS IS PART OF
CRN *OC21140.5*
Technical Standards & Safety Authority
Ballast & Pressure Vessels
Safety Program