

Lift Check Valves

50 Series

Swagelok® lift check valves limit reverse flow under pressures up to 6000 psig (413 bar) and temperatures up to 900°F (482°C).

Forward flow lifts the poppet, opening the valve. Reverse flow seats the poppet against the orifice, closing the valve.

The lift check valve is gravity assisted and must be mounted horizontally, with bonnet nut on top.

Features

- Rugged, all-stainless steel construction
- Reverse flow coefficient less than 0.1 % of forward flow coefficient
- No springs or elastomers
- Compact size

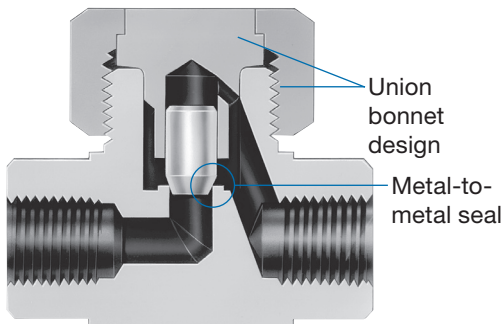

Pressure-Temperature Ratings

ASME Class	2500
Material Group	2.2
Material Name	316 SS
Temperature °F (°C)	Working Pressure psig (bar)
-65 (-53) to 100 (37)	6000 (413)
200 (93)	5160 (355)
250 (121)	4910 (338)
300 (148)	4660 (321)
350 (176)	4470 (307)
400 (204)	4280 (294)
450 (232)	4130 (284)
500 (260)	3980 (274)
600 (315)	3760 (259)
650 (343)	3700 (254)
700 (371)	3600 (248)
750 (398)	3520 (242)
800 (426)	3460 (238)
850 (454)	3380 (232)
900 (482)	3280 (225)

For more information about pressure ratings of valves with tube fitting end connections, refer to *Tubing Data* catalog, [MS-01-107](#).

Materials of Construction

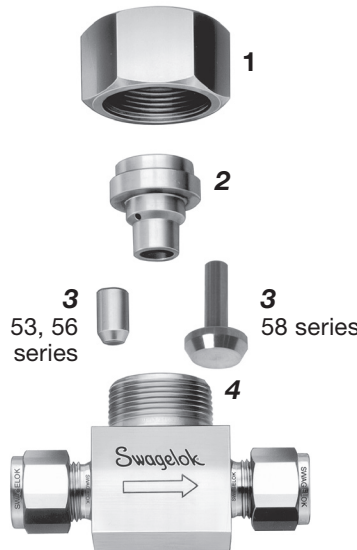

Component	Material Grade/ASTM Specification
1 Bonnet nut	316 SS/A479
2 Bonnet	316 SS/A479
3 Poppet	S17400/A564
4 Body	316 SS/A479
Lubricant	Nickel-based

Wetted components listed in *italics*.

Testing

Every Swagelok lift check valve is factory tested for proper operation.

Cleaning and Packaging

All Swagelok lift check valves are cleaned and packaged in accordance with Swagelok *Standard Cleaning and Packaging (SC-10)* catalog, [MS-06-62](#).

Oxygen Service Hazards

For more information about hazards and risks of oxygen-enriched systems, refer to *Oxygen System Safety* technical report, [MS-06-13](#).

Flow Data at 100°F (37°C)

Air

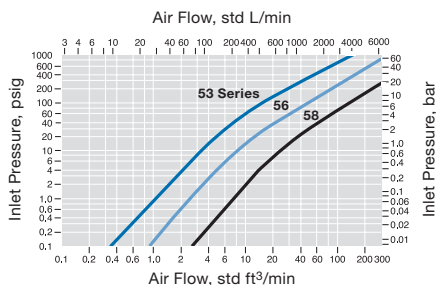

Water

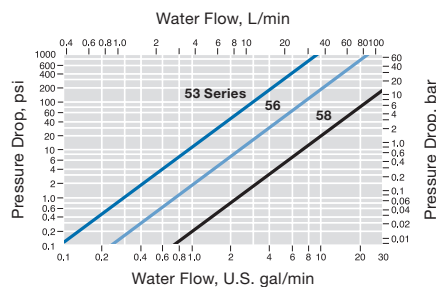

Options

Special Cleaning and Packaging (SC-11)

To order lift check valves cleaned and packaged in accordance with *Special Cleaning and Packaging (SC-11)* catalog, [MS-06-63](#), to ensure compliance with product cleanliness requirements stated in ASTM G93 Level C, add **-SC11** to the valve ordering number.

Example: SS-53S4-SC11

Special Alloys

Many valve bodies are available in other alloys. Contact your authorized Swagelok sales and service representative for more information.

Ordering Information and Dimensions

Select an ordering number.

Dimensions are for reference only and are subject to change.

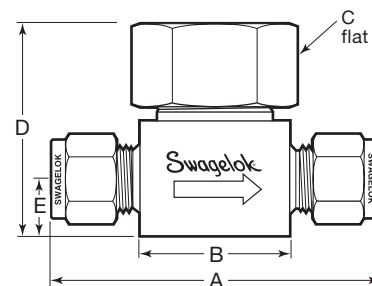

End Connections		C _v	Orifice in. (mm)	Ordering Number	Series	Dimensions, in. (mm)				
Inlet/Outlet	Size					A	B	C	D	E
Swagelok tube fittings	1/4 in.	0.30	0.156 (4.0)	SS-53S4	53	2.40 (61.0)	1.01 (25.7)	7/8	1.47 (37.3)	0.39 (9.9)
	3/8 in.	0.64	0.250 (6.4)	SS-56S6	56	2.83 (71.9)	1.31 (33.3)	1 1/4	1.85 (47.0)	0.50 (12.7)
	1/2 in.	2.20	0.437 (11.1)	SS-58S8	58	3.92 (99.6)	2.19 (55.6)	1 1/2	2.44 (62.0)	0.62 (15.7)
	3/4 in.			SS-58S12						
	6 mm	0.30	0.156 (4.0)	SS-53S6MM	53	2.40 (61.0)	1.01 (25.7)	7/8	1.47 (37.3)	0.39 (9.9)
Female NPT	1/8 in.	0.30	0.156 (4.0)	SS-53F2	53	2.00 (50.8)	1.00 (25.4)	7/8	1.47 (37.3)	0.39 (9.9)
	1/4 in.			SS-53F4		2.06 (52.3)	0.94 (23.9)			
	1/4 in.	0.64	0.250 (6.4)	SS-56F4	56	2.25 (57.2)	1.25 (31.8)	1 1/4	1.85 (47.0)	0.50 (12.7)
	3/8 in.	2.20	0.437 (11.1)	SS-58F6	58	3.12 (79.2)	1.86 (47.2)	1 1/2	2.44 (62.0)	0.62 (15.7)
	1/2 in.			SS-58F8						
Tube socket weld or pipe butt weld	1/4 in.	0.30	0.156 (4.0)	SS-53SW4T	53	1.81 (46.0)	0.90 (22.9)	7/8	1.47 (37.3)	0.39 (9.9)
	3/8 in.	0.64	0.250 (6.4)	SS-56SW6T	56	2.25 (57.2)	1.25 (31.8)	1 1/4	1.85 (47.0)	0.50 (12.7)
	1/2 in.			SS-56SW8T						
	1/2 in.	2.20	0.437 (11.1)	SS-58SW8T	58	3.13 (79.5)	1.88 (47.8)	1 1/2	2.44 (62.0)	0.62 (15.7)
Swagelok tube fitting/ female NPT	1/4 in.	0.30	0.156 (4.0)	SS-53S4-F4	53	2.23 (56.6)	0.97 (24.6)	7/8	1.47 (37.3)	0.39 (9.9)

Dimensions shown with Swagelok nuts finger-tight.

Sour Gas Service

Lift check valves are available for sour gas service. Materials are selected in accordance with NACE MR0175/ISO 15156.

Technical Data

Pressure Rating at 70°F (20°C)

6000 psig (413 bar)

Temperature Rating

-65 to 500°F (-53 to 260°C)

Materials of Construction

Poppet—alloy 400/B164

All other materials and lubricant same as standard product. See **Materials of Construction**, page 1.

Safe Product Selection

When selecting a product, the total system design must be considered to ensure safe, trouble-free performance. Function, material compatibility, adequate ratings, proper installation, operation, and maintenance are the responsibilities of the system designer and user.

 WARNING

Do not mix/interchange Swagelok products or components not governed by industrial design standards, including Swagelok tube fitting end connections, with those of other manufacturers.

Warranty Information

Swagelok products are backed by The Swagelok Limited Lifetime Warranty. For a copy, visit swagelok.com or contact your authorized Swagelok representative.

Swagelok—TM Swagelok Company
© 2002–2021 Swagelok Company
MS-01-98, RevK, November 2021