

Proportional Safety Relief Valves

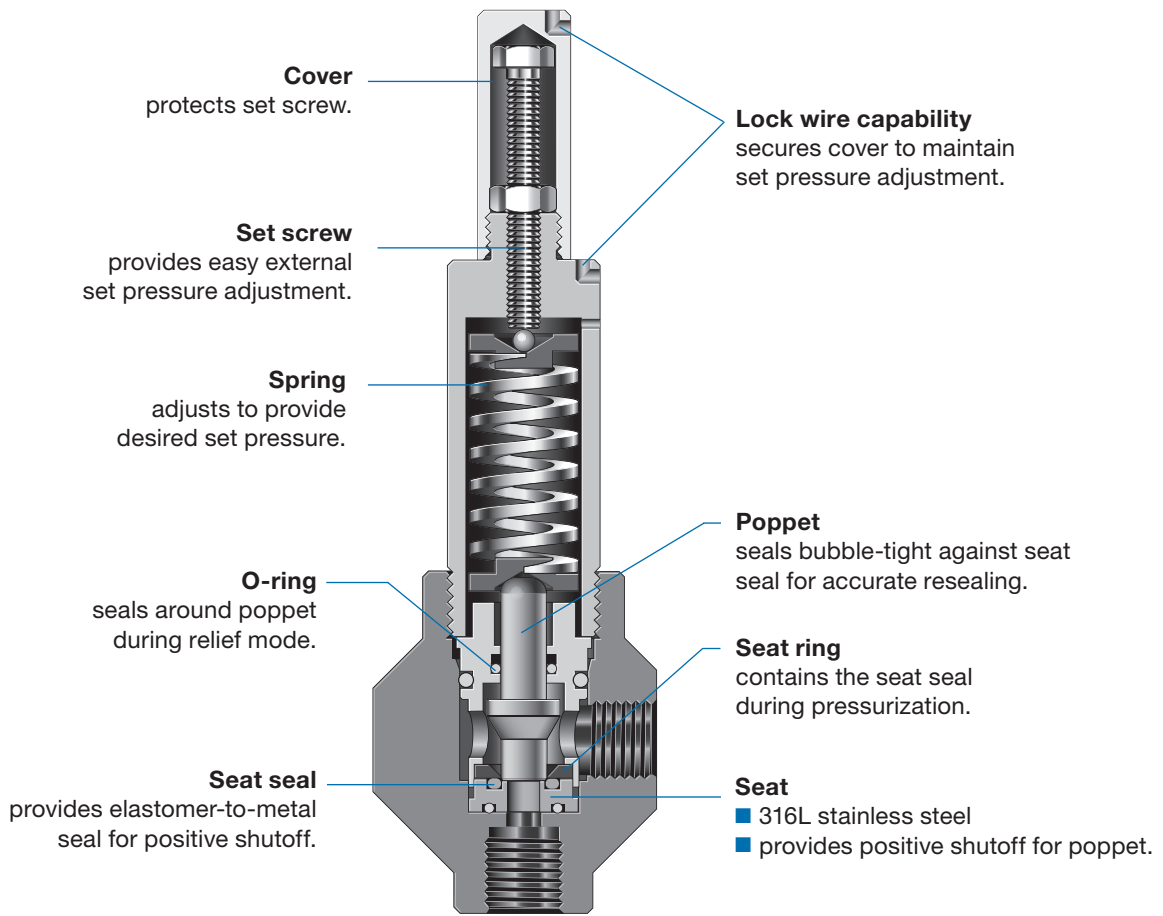

PRV Series

- Gas and liquid service
- Working pressure: 6000 psig (413 bar)
- Set pressures from 145 to 6000 psig (10.0 to 413 bar)
- All 316L stainless steel construction
- 1/4 through 1 in. NPT and ISO/BSP parallel thread end connections
- Certified to PED 2014/68/EU Category IV



Features

- All 316L stainless steel wetted metal components
- Five set spring pressure ranges
- Factory-set, tested, locked, and tagged with the set pressure
- CE-marked in accordance with the Pressure Equipment Directive as a safety valve according to ISO-4126-1
- Available integral end connections—1/4 and 3/4 in. female NPT and ISO/BSP parallel thread
- Available end connection adapters—1/2 in. male and female NPT and ISO/BSP parallel thread, 3/4 in. male NPT, and 1 in. male and female NPT and ISO/BSP parallel thread end connections

Applications

PRV series relief valves are proportional safety relief valves that open gradually as the pressure increases above the set pressure.

⚠ Swagelok® proportional relief valves should never be used as safety relief devices in steam applications such as ASME Boiler and Pressure Vessel Code Section I, Power Boilers.

Operation

PRV series relief valves OPEN when system pressure reaches the set pressure, and CLOSE when system pressure falls below the set pressure.

⚠ For valves not actuated for a period of time, initial relief pressure may be different than the set pressure.

Technical Data

Valve Series	PRV2	PRV6
Working Pressure, psig (bar)	6000 (413)	
Set Pressure, psig (bar)	145 to 5290 (10.0 to 365)	145 to 6000 (10.0 to 413)
Temperature, °F (°C)	Fluorocarbon FKM seal material: 5 to 176 (-15 to 80) Nitrile seal material: -4 to 176 (-20 to 80)	
Seal Materials	Fluorocarbon FKM and nitrile	
Flow Coefficient (C _v)	0.49	4.36
Seat Diameter, in. (mm)	0.20 (5.0)	0.45 (11.5)
Weight, lb (kg)	1.7 (0.77)	5.7 (2.6)

Set Pressure and Resealing Pressure

- Set pressure is the upstream pressure at which the first indication of flow occurs. Set pressure of each valve after initial relief is repeatable within $\pm 5\%$ at room temperature.
- Resealing pressure is the upstream pressure at which there is no indication of flow. Resealing pressure is always lower than set pressure. See table below for details.
- Blowdown is the difference between the set pressure and the resealing pressure. It is usually expressed as a percentage of the set pressure.

Set Pressure psig (bar)	Minimum Resealing Pressure as a Percentage of Set Pressure, %
2900 (200)	95
1450 (100)	90
724 (50.0)	85
362 (25.0)	80

Testing

Every PRV series proportional safety relief valve is tested for shell, set, and resealing performance.

Cleaning and Packaging

All Swagelok PRV series proportional safety relief valves are cleaned and packaged in accordance with *Standard Cleaning and Packaging (SC-10)*, [MS-06-62](#).

Materials of Construction

PRV2 Series Relief Valve

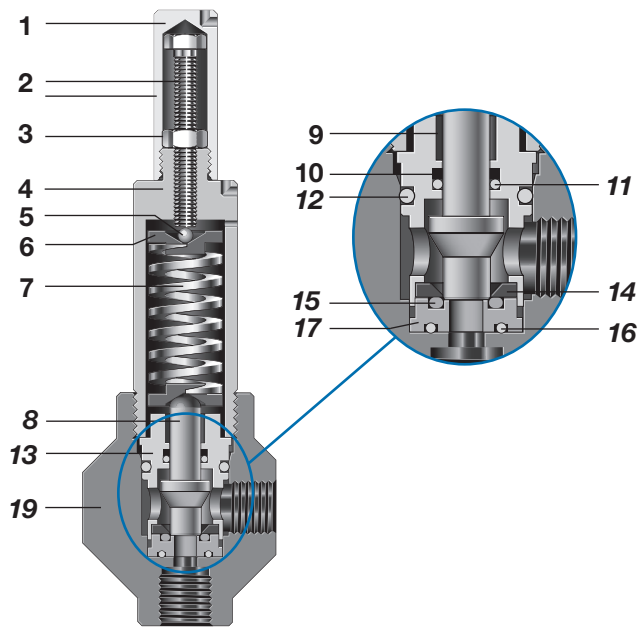

PRV6 Series Relief Valve

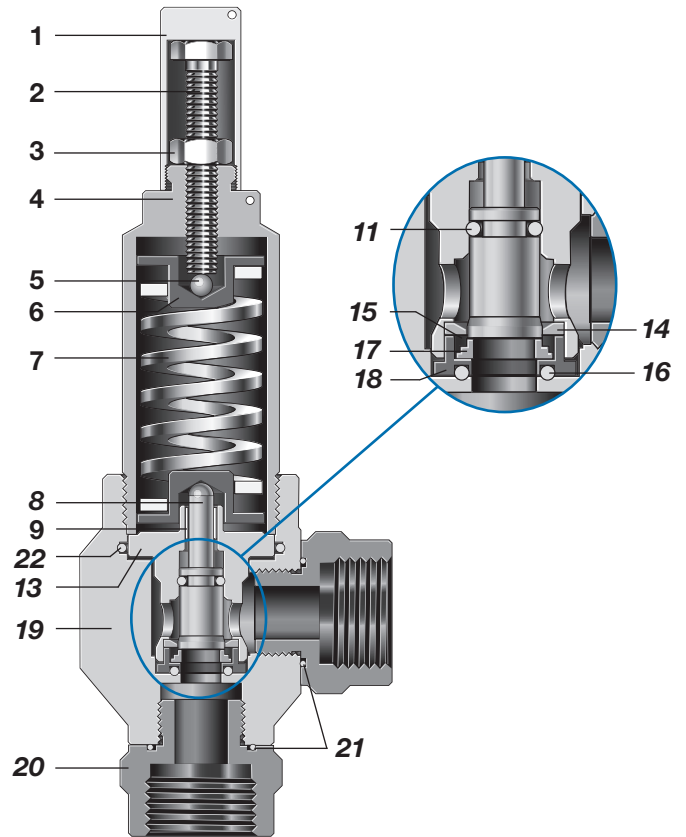

Component	Material Grade / ASTM Specification
1 Cover	316L SS / A479, EN10088
2 Set screw	A2-70
3 Nut	A2
4 Spring housing	316L SS / A479
5 Ball	420 stainless steel
6 Spring guide	316L SS / A479
7 Set spring	CR50V4
8 Poppet	316L SS / A479, EN10088
9 Bearing	Carbon- and PTFE-filled polyamide
10 Backup ring (PRV2 only)	PTFE
11 O-ring	<i>Nitrile, fluorocarbon FKM</i>
12 O-ring	
13 Poppet housing	316L SS / A479, EN10088
14 Seat ring	
15 Seat seal	
16 O-ring	
17 Seat	316L SS / A479, EN10088
18 Seat housing (PRV6 only)	
19 Body	
20 Adapters (PRV6 only)	<i>Nitrile, fluorocarbon FKM</i>
21 O-ring	
22 O-ring	
Lubricants	<i>Molybdenum disulfide-based dry film and paste; silicone-based</i>

Wetted components listed in *italics*.

Flow Data at 70°F (20°C)

PRV2 Series

Flow rates are based on testing of PRV2 series valves with 1/4 in. female NPT end connections.

Set Pressure—0 to 2175 psig (0 to 150 bar)

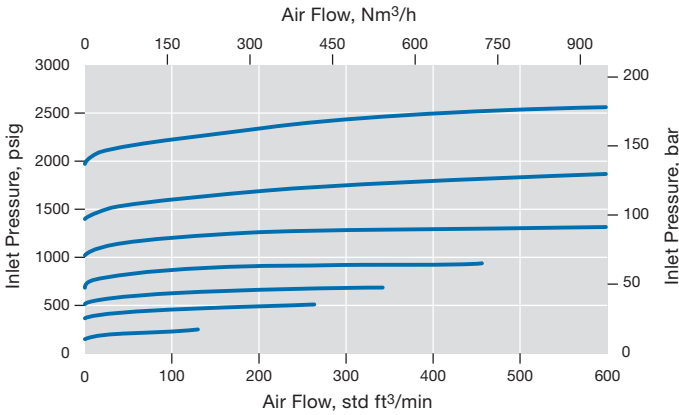

Set Pressure—2175 to 5290 psig (150 to 365 bar)

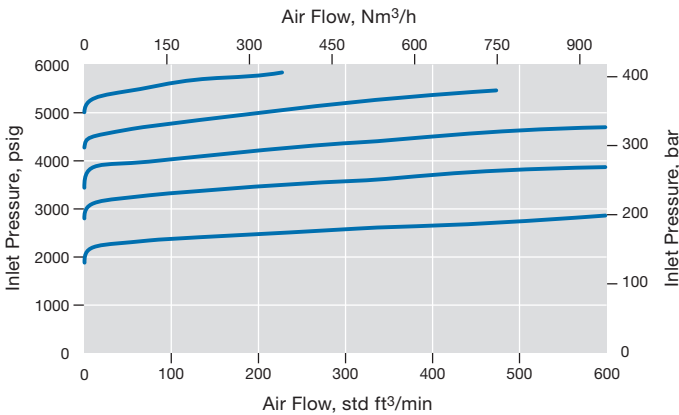

Certified Discharge Coefficient

Set Pressure Range psig (bar)	Certified Discharge Coefficient (K_{dr})			
	PRV2 Series		PRV4/6/8 Series	
	Gas	Liquid	Gas	Liquid
145 to 580 (10.0 to 40.0)	0.035	0.032	0.027	0.050
580 to 1160 (40.0 to 80.0)				
1160 to 2175 (80.0 to 150)				
2175 to 4060 (150 to 280)	0.070	0.032	0.027	0.036
4060 to 5290 (280 to 365)				
5290 to 6000 (365 to 413)	—	—	0.027	0.036

PRV6 Series

Flow rates are based on testing of PRV6 series valves with 3/4 in. female ISO/BSP end connections.

Set Pressure—0 to 750 psig (0 to 50 bar)

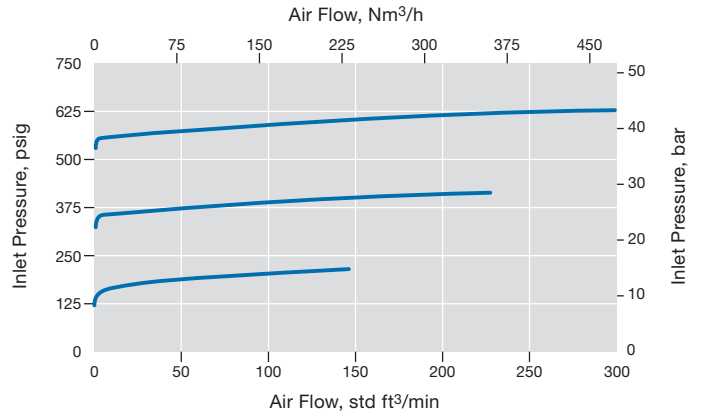

Set Pressure—1000 to 3000 psig (70 to 200 bar)

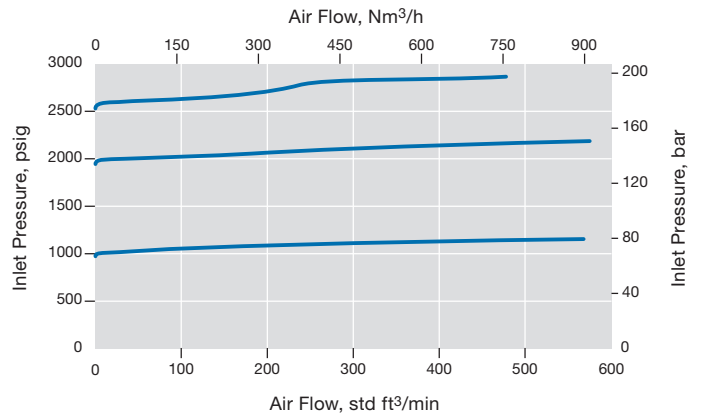

Set Pressure—3000 to 6000 psig (200 to 413 bar)

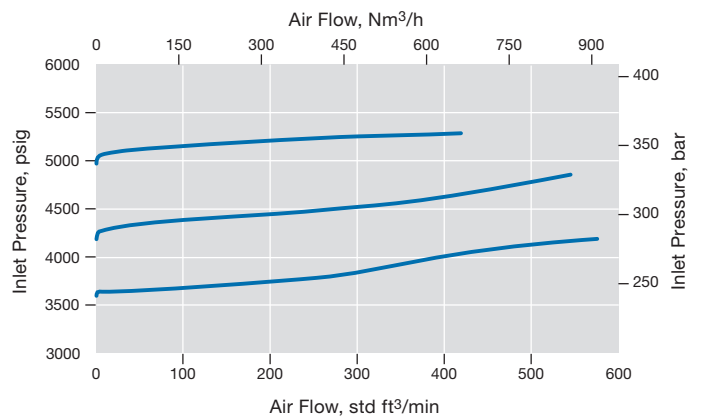

Dimensions

Dimensions are for reference only and are subject to change.

End Connections		Dimensions, in. (mm)			
Inlet / Outlet	Size	A	B	C	D Dia
PRV2 Series					
Female NPT	1/4 in.	6.13 (156)	1.18 (30.0)	0.91 (23.0)	2.05 (52.0)
Female ISO/BSP parallel thread					
PRV6 Series					
Male ISO/BSP parallel thread	1/2 in.	9.89 (252)	2.62 (66.5)	2.22 (56.5)	2.91 (74.0)
Female NPT	3/4 in.	8.87 (226)	1.59 (40.5)	1.20 (30.5)	
Female ISO/BSP parallel thread					
Male ISO/BSP parallel thread	1 in.	9.97 (254)	2.70 (68.5)	2.30 (58.5)	
Female ISO/BSP parallel thread					

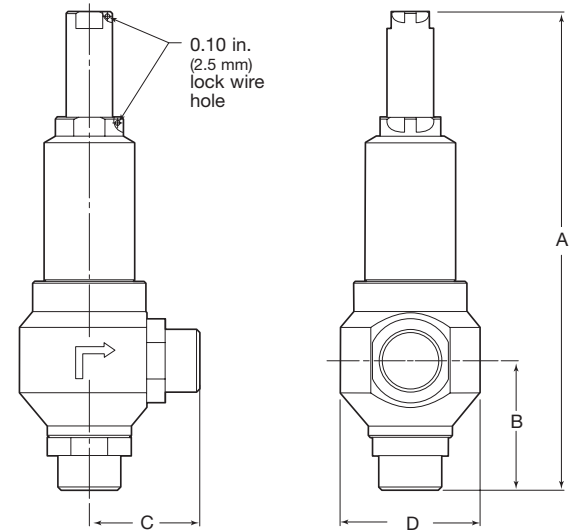

PRV6 series valve shown

Ordering Information

Build a PRV series relief valve ordering number by combining the designators in the sequence shown below.

1 2 3 4 5 6 7 8 9
PRV B 2 F - 02 - 0 - V V - Q

1 Series

PRV = 6000 psig (413 bar) maximum inlet pressure

2 Inlet / Outlet

B = ISO/BSP parallel thread
N = NPT

3 End Connection Size

PRV2 series

2 = 1/4 in.

PRV6 series

4 = 1/2 in. adapter, 3/4 in. main body

6 = 3/4 in.

8 = 1 in. adapter, 3/4 in. main body

4 End Connection Thread Style

M = Male
F = Female

5 Body Material

02 = 316L SS

6 Set Pressure Range

0 = 145 to 580 psig (10.0 to 40.0 bar)

1 = 580 to 1160 psig (40.0 to 80.0 bar)

2 = 1160 to 2175 psig (80.0 to 150 bar)

3 = 2175 to 4060 psig (150 to 280 bar)

PRV2 series

4 = 4060 to 5290 psig (280 to 365 bar)

PRV6 series

4 = 4060 to 6000 psig (280 to 413 bar)

7 Seal Material

V = Fluorocarbon FKM
N = Nitrile

8 Seat Seal Material

V = Fluorocarbon FKM
N = Nitrile

9 Options

Omit designator if option is not ordered.

Q = Independent 3rd party witness testing of set pressure

Options and Accessories

Spring Kits

Series	Spring Kit Basic Ordering Number
PRV2	Contact your authorized Swagelok representative
PRV4/6/8	SS-13K-PRV6-

PRV4/6/8 spring kits include spring and installation instructions.

To order, add the spring designator for the desired set pressure range shown below to the basic ordering number.

Example: SS-13K-PRV6-0

Spring Set Pressure Ranges

Set Pressure Range psig (bar)	Spring Designator
145 to 580 psig (10.0 to 40.0 bar)	0
580 to 1160 psig (40.0 to 80.0 bar)	1
1160 to 2175 psig (80.0 to 150 bar)	2
2175 to 4060 psig (150 to 280 bar)	3
PRV2 Series: 4060 to 5290 psig (280 to 365 bar) PRV4/6/8 Series: 4060 to 6000 psig (280 to 413 bar)	4

Poppet Seal Kits

Series	Seal Material	Poppet Seal Kit Ordering Number
PRV2	Fluorocarbon FKM	Contact your authorized Swagelok representative
	Nitrile	
PRV4/6/8	Fluorocarbon FKM	PRV4/6/8-02-VV-3K
	Nitrile	PRV4/6/8-02-NN-3K

PRV4/6/8 poppet seal kits include O-rings, seat seal, poppet, and installation instructions.

To order poppet seal kits for PRV series relief valves purchased from RHPS B.V. having S numbers lower than 4600, contact your authorized Swagelok representative. For S numbers 4600 and higher, select the kit from the table above.

End Connection O-Ring Seals

Series	Seal Material	End Connection O-Ring Seal Ordering Number
PRV4/6/8	Fluorocarbon FKM	FCN-90-OR-025-BG
	Nitrile	BN-90-OR-025-BG

Order one O-ring for each end connection as needed.

Optional Certification

Optional independent third-party witness testing of set pressure testing is available upon request. To order, add **-Q** to the valve ordering number.

Example: PRVB4F-02-0-VV-**Q**

Additional Products.

- For additional Swagelok relief valves, see the *Proportional Relief Valves* catalog, MS-01-141.



- For Swagelok pressure gauges, see the *Industrial and Process Pressure Gauges* catalog, MS-02-170.



- For Swagelok tube fitting products, see the *Gaugeable Tube Fittings and Adapter Fittings* catalog, MS-01-140.



Safe Product Selection

When selecting a product, the total system design must be considered to ensure safe, trouble-free performance. Function, material compatibility, adequate ratings, proper installation, operation, and maintenance are the responsibilities of the system designer and user.

WARNING

Do not mix/interchange Swagelok products or components not governed by industrial design standards, including Swagelok tube fitting end connections, with those of other manufacturers.

Warranty Information

Swagelok products are backed by The Swagelok Limited Lifetime Warranty. For a copy, visit swagelok.com or contact your authorized Swagelok representative.