

Assembly-by-Torque (AbT) Fittings

Designed for the Alternative Fuels Industry



- Quick and easy installation
- Metal-to-metal seal
- ECE R110, ISO 15500 and NGV 3.1 approved
- Consistent reassemblies
- Excellent vibration fatigue resistance

Swagelok® Assembly-by-Torque (AbT) Fittings

Since 1947, Swagelok has designed, developed, and manufactured high-quality fluid system components. We are committed to meeting the evolving needs of global industries with a broad range of products and services.

This catalog covers products suitable for applications in the Alternative Fuels industry. On the following pages you will find technical and ordering information on Assembly-by-Torque (AbT) Fittings. These products have the following characteristics:

Features

- Excellent gas-tight sealing and tube-gripping action
- Easily achieved proper installation
- Excellent vibration fatigue resistance
- Double-notch nut provides visual differentiation from standard Swagelok fittings
- Repeated reassembly by torque—seal performance is maintained through repeated reassemblies

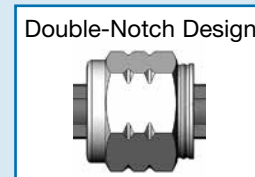

Offering reliable and repeatable assembly methods, the assembly-by-torque (AbT) fitting assembles quickly. Assembly to a pre-determined torque facilitates reliability and repeatability of fitting assemblies. In tight spaces, the AbT fitting can be assembled by hand, with no special tools required. For difficult-to-reach or confined space applications, preswaging prior to assembly eases installation and speeds up production.

Swagelok AbT fittings utilize a unique stop feature, known as a dynamic zone (patented), integrated into the highly-reliable, widely used, Swagelok tube fitting. In all sizes, the design controls axial displacement of the nut during assembly and disassembly.

Advanced-Geometry, Hinging-Colleting Back Ferrule Design

The advanced geometry, hinging-colleting back ferrule design is standard on all stainless steel Swagelok AbT tube fittings to help installers make consistent, leak-tight tube connections.

The patented case hardening process and patented recessed and contoured geometry provide unique engineering to the Swagelok back ferrule. The hinging-colleting back ferrule design provides the robust performance of the Swagelok ferrule design.

For additional information, see the *316 Stainless Steel Swagelok Tube Fittings with Advanced Geometry Back Ferrules* technical report, [MS-06-16](#).

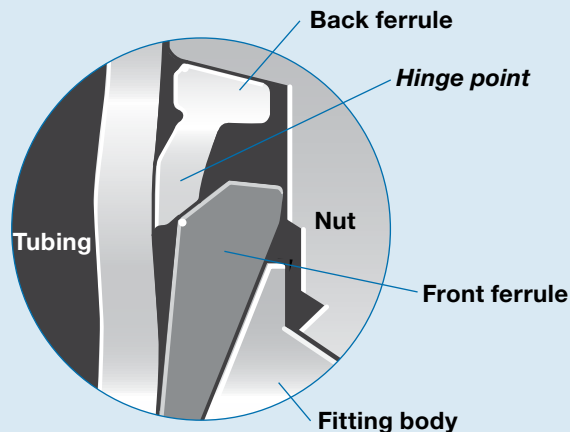

How It Works

The Swagelok AbT tube fitting is based on the advanced-geometry, hinging-colleting back ferrule tube fitting with additional features. The patented fitting allows for assembly by torque, which provides a consistent leak-tight performance across the installation torque range.

After a preswaged tubing assembly is inserted into a fitting body, the AbT nut is tightened to the appropriate torque value. The dynamic zone on the nut provides resistance as the connection reaches the predetermined pull-up position and torque range.

Note: Preswaging is required for all AbT connections.

Installation Inspection

Visual confirmation of completed pull-up when the dynamic zone makes contact with the shoulder of the fitting body.

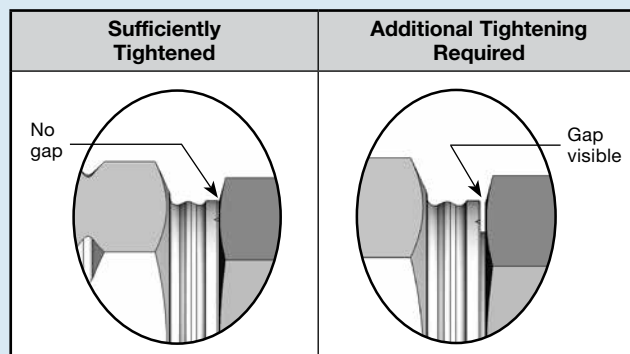

Contents

Swagelok AbT Fittings

**1/4 in., 3/8 in., 1/2 in.,
6 mm, 8 mm, 10 mm, and 12 mm**

Features, 4

Materials of Construction, 5

Pressure Ratings, 5

Cleaning and Packaging, 5

**Ordering Information and
Dimensions, 6**

Tools and Accessories, 9

Installation Instructions, 10

Assembly-by-Torque (AbT) Tube Fittings

AbT fittings feature a patented dynamic zone feature on the nut which provides a prescribed resistance, at a predetermined position, during the assembly-by-torque installation pull-up. **These unique nut and ferrule sets can be assembled to standard Swagelok tube fitting bodies to create an assembly-by-torque tube fitting.**

Features

- Assembly by torque.
- Sizes: 1/4 in., 3/8 in., 1/2 in., 6 mm, 8 mm, 10 mm, and 12 mm
- Meets the requirements of NGV 3.1, ISO 15500, and ECE R110.
- For use on standard fittings and valve bodies as well as AbT bulkhead bodies. (Not intended for use with standard bulkhead bodies.)
- Visual confirmation on initial assembly.

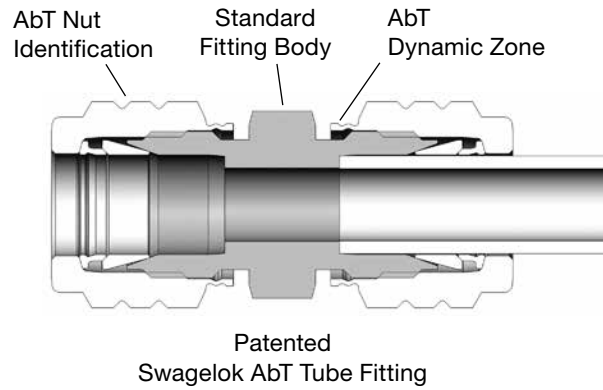

Alternative Fuels Certification

Stainless steel Swagelok AbT tube fittings as shown in the table below have been tested to the requirements of ECE R110, ISO 15500, and NGV 3.1.

Swagelok Fitting Size	Tube Size OD × Wall	Series	Tubing Material
Fractional, in.			
1/4	1/4 × 0.028	400 ABT	316/316L SS 304/304L SS
	1/4 × 0.035		
	1/4 × 0.049		
3/8	3/8 × 0.049	600 ABT	
	3/8 × 0.065		
1/2	1/2 × 0.049	810 ABT	
	1/2 × 0.065		
	1/2 × 0.083		
Metric, mm			
6	6 × 1.0	6M0 ABT	
8	8 × 1.0	8M0 ABT	
	8 × 1.2		
10	10 × 1.0	10M0 ABT	
	10 × 1.5		
12	12 × 1.5	12M0 ABT	
	12 × 1.8		

Pressure-Temperature Ratings

Careful selection of high-quality tubing is important to installing safe, leak-tight systems.

Temperature °F (°C)	AbT Fitting Body Unions: Straight, Elbow, Tee, Cross			
	Series	Tube OD	Tube Wall Thickness	Working Pressure psig (bar)
Fractional, in.				
-40 (-40) to 100 (37)	400 ABT	1/4	0.028	4000 (275)
			0.035	5100 (351)
			0.049	7500 (516)
	600 ABT	3/8	0.049	4800 (330)
			0.065	6500 (447)
	810 ABT	1/2	0.049	3700 (254)
			0.065	5100 (351)
			0.083	6700 (461)
	200 (93)	400 ABT	1/4	0.028
0.035				5100 (351)
0.049				7500 (516)
600 ABT		3/8	0.049	4800 (330)
			0.065	6500 (447)
810 ABT		1/2	0.049	3700 (254)
			0.065	5100 (351)
			0.083	6700 (461)
248 (120)		400 ABT	1/4	0.028
	0.035			5049 (347)
	0.049			7425 (511)
	600 ABT	3/8	0.049	4752 (327)
			0.065	6435 (443)
	810 ABT	1/2	0.049	3663 (252)
			0.065	5049 (347)
			0.083	6633 (461)
	Metric, mm			
-40 (-40) to 100 (37)	6M0 ABT	6	1.0	6092 (419)
			1.2	5100 (351)
	8M0 ABT	8	1.0	4500 (310)
			1.2	5100 (351)
	10M0 ABT	10	1.0	3480 (239)
			1.5	5100 (351)
	12M0 ABT	12	1.5	4790 (330)
			1.8	5100 (351)
200 (93)	6M0 ABT	6	1.0	6092 (419)
			1.2	5100 (351)
	8M0 ABT	8	1.0	4500 (310)
			1.2	5100 (351)
	10M0 ABT	10	1.0	3480 (239)
			1.5	5100 (351)
	12M0 ABT	12	1.5	4790 (330)
			1.8	5100 (351)
248 (120)	6M0 ABT	6	1.0	6031 (415)
			1.2	5049 (347)
	8M0 ABT	8	1.0	4455 (306)
			1.2	5049 (347)
	10M0 ABT	10	1.0	3445 (237)
			1.5	5049 (347)
	12M0 ABT	12	1.5	4742 (326)
			1.8	5049 (347)

Temperature °F (°C)	SAE/MS Designator	Working Pressure, psig (bar)	
		Nonpositionable	Positionable
-40 (-40) to 100 (37)	4ST	4568 (314)	4568 (314)
	5ST		3626 (249)
	6ST		
	8ST		
200 (93)	4ST	4568 (314)	4568 (314)
	5ST		3626 (249)
	6ST		
	8ST		
248 (120)	4ST	4522 (311)	4522 (311)
	5ST		3589 (247)
	6ST		
	8ST		

Materials of Construction

Component	Material/Specification
Nut	316 SS/ASTM A276,
Back ferrule	ASME SA479, EN 1.4401
Front ferrule	316 SS/ASTM A276,
Body, bar stock	ASME SA479, EN 1.4401
Body, forging	316 SS/ASTM A182,
	ASME SA182, EN 1.4401
Lubricant	Hydrocarbon-based dry film

Wetted components listed in *italics*.

Cleaning and Packaging

All Swagelok AbT tube fittings are cleaned in accordance with Swagelok *Standard Cleaning and Packaging (SC-10)* catalog, [MS-06-62](#).

Ordering Numbers and Dimensions

Dimensions are for reference only and are subject to change. Dimensions shown with Swagelok AbT nuts finger-tight. Additional configurations are available on request. Contact your authorized Swagelok sales and service representative.

AbT Nut and Ferrule Set (sold separately for easy installation)

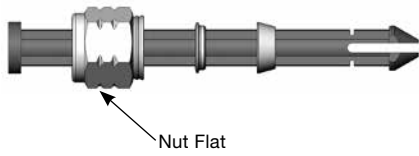

Tube OD	Ordering Number ^①	Sets per Arbor	Dimension
			Nut Flat
Fractional, in.			
1/4	SS-4ABT-NFSET	5	9/16 in.
3/8	SS-6ABT-NFSET	5	11/16 in.
1/2	SS-8ABT-NFSET	5	7/8 in.
Metric, mm			
6	SS-6MABT-NFSET	5	14 mm
8	SS-8MABT-NFSET	5	5/8 in.
10	SS-10MABT-NFSET	5	3/4 in.
12	SS-12MABT-NFSET	5	22 mm

^① Order by Arbor.

Ordering Numbers and Dimensions

AbT Bulkhead Body

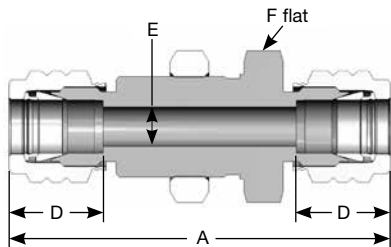

Tube OD	Ordering Number ^{①②}	Dimensions							
		A	D	E	F	Panel Hole Size	Max Panel Thickness	Bulkhead Thread Size	Panel Nut (order separately)
Fractional, in.									
1/4	SS-4ABT0-61BO	2.32	0.60	0.19	3/4 in.	37/64	0.44	9/16-20	SS-602-61
3/8	SS-6ABT0-61BO	2.71	0.67	0.28	15/16 in.	49/64	0.60	3/4-20	SS-812-61
1/2	SS-8ABT0-61BO	3.13	0.90	0.41	1 3/16 in.	1 1/64	0.75	1-20	SS-1212-61
Metric, mm									
6	SS-6MABT0-61BO	60.0	15.3	4.8	22 mm	16.3	11.1	5/8-20	SS-10M2-61
8	SS-8MABT0-61BO	62.7	16.2	6.3	15/16 in.	19.5	11.0	3/4-20	SS-12M2-61
10	SS-10MABT0-61BO	72.1	17.0	7.9	1 1/16 in.	22.8	15.2	7/8-20	SS-16M2-61
12	SS-12MABT0-61BO	81.2	22.8	9.5	1 3/16 in.	26.0	19.0	1-20	SS-18M2-61

① Requires two AbT nut and ferrule sets – ordered separately.

② Panel nut ordered separately.

AbT Union Body

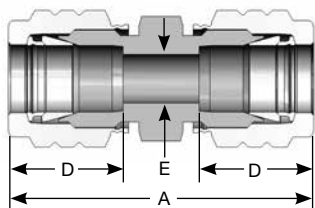

Tube OD in.	Ordering Number ^①	Dimensions		
		A	D	E
Fractional, in.				
1/4	SS-400-6BO	1.61	0.60	0.19
3/8	SS-600-6BO	1.79	0.67	0.28
1/2	SS-810-6BO	2.01	0.90	0.41
Metric, mm				
6	SS-6M0-6BO	41.0	15.3	4.8
8	SS-8M0-6BO	43.2	16.2	6.4
10	SS-10M0-6BO	45.8	17.0	7.9
12	SS-12M0-6BO	51.2	22.8	9.5

① Requires two AbT nut and ferrule sets – ordered separately.

AbT Cross Body

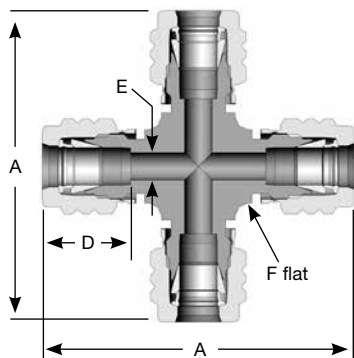

Tube OD in.	Ordering Number	Dimensions			
		A	D	E	F, in.
Fractional, in.					
1/4	SS-400-4BO	2.12	0.60	0.19	1/2
Metric, mm					
6	SS-6M0-4BO	53.9	15.3	4.8	1/2

Ordering Numbers and Dimensions

AbT Tee Union Body

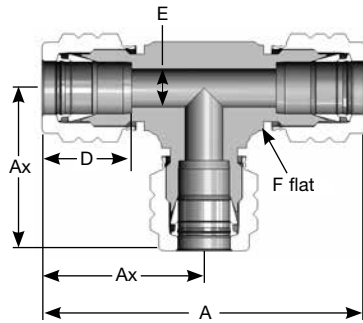

Tube OD in.	Ordering Number ^①	Dimensions				
		A	Ax	D	E	F, in.
Fractional, in.						
1.4	SS-400-3BO	2.12	1.06	0.60	0.19	1/2
3/8	SS-600-3BO	2.42	1.21	0.67	0.28	5/8
1/2	SS-810-3BO	2.84	1.42	0.90	0.41	13/16
Metric, mm						
6	SS-6M0-3BO	53.9	27.0	15.3	4.8	1/2
8	SS-8M0-3BO	59.7	29.9	16.2	6.4	5/8
10	SS-10M0-3BO	62.6	31.3	17.0	7.9	11/16
12	SS-12M0-3BO	72.0	36.0	22.8	9.5	13/16

① Requires three AbT nut and ferrule sets – ordered separately.

AbT Elbow Union Body

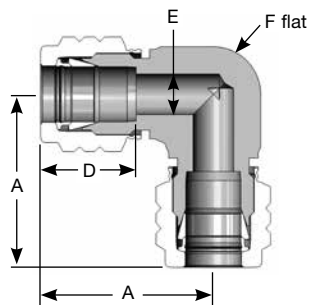

Tube OD in.	Ordering Number ^①	Dimensions			
		A	D	E	F, in.
Fractional, in.					
1/4	SS-400-9BO	1.06	0.60	0.19	1/2
3/8	SS-600-9BO	1.21	0.67	0.28	5/8
1/2	SS-810-9BO	1.42	0.90	0.41	13/16
Metric, mm					
6	SS-6M0-9BO	27.0	15.3	4.8	1/2
8	SS-8M0-9BO	28.8	16.2	6.4	9/16
10	SS-10M0-9BO	31.3	17.0	7.9	11/16
12	SS-12M0-9BO	36.0	22.8	9.5	13/16

① Requires two AbT nut and ferrule sets – ordered separately.

AbT Male Connector Body SAE/MS Straight Thread (ST)

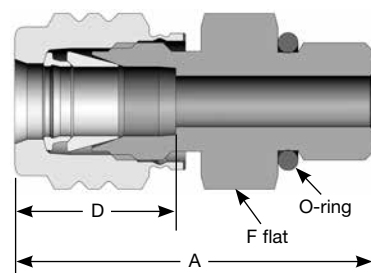

Tube OD in.	SAE/MS Thread Size	Ordering Number ^{①②}	Dimensions			
			A	D	E ^③	F
Fractional, in.						
1/4	7/16-20	SS-400-1-4STDEBO	1.34	0.60	0.19	9/16
Metric, mm						
6	7/16-20	SS-6M0-1-4STDEBO	25.6	15.3	4.8	14
6	9/16-18	SS-6M0-1-6STDEBO	23.0	15.3	4.8	18

① Requires one AbT nut and ferrule set – ordered separately.

② The o-ring materials is fluorocarbon FKM in accordance with ECE R110 and ECE R67.

③ The E dimension is the minimum nominal opening. These fittings may have a larger opening at the pipe/straight thread end.

Tools and Accessories

AbT Manual Preswaging Tool

For Swagelok ABT tube fitting installations.

Note: Preswaging is required for all AbT connections.

Features



- Preswages ferrules onto the tube
- Standardizes assembly procedure for repeatable installation
- Enables the installer to work in a more open, safe area
- Is designed with a blue ring (fractional) or yellow ring (metric) to distinguish it from other tools.

Ordering Information

Tube OD	Ordering Number
Fractional, in.	
1/4	MS-ST-400-ABT
3/8	MS-ST-600-ABT
1/2	MS-ST-810-ABT
Metric, mm	
6	MS-ST-6M0-ABT
8	MS-ST-8M0-ABT
10	MS-ST-10M0-ABT
12	MS-ST-12M0-ABT

High Volume AbT Swaging Unit (HVSU)

For Swagelok ABT tube fitting installations.

Note: Preswaging is required for all AbT connections.

Features

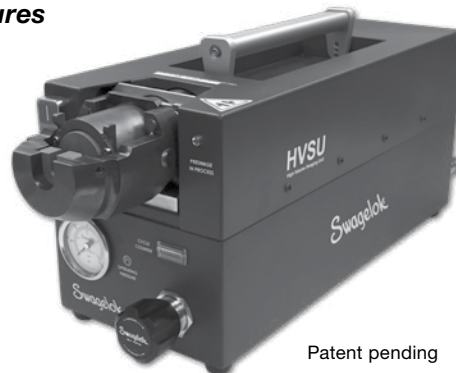

Patent pending

- Preswages Swagelok tube fitting ferrules onto tubing prior to assembly
- Reduces assembly and installation time
- Improves process controls
 - Starts automatically when tubing is inserted and properly bottomed
 - Prevents over swaging with stroke-limiting tooling
- High cycle life
- Easy to switch from one tube fitting size to another—no tools are needed to change sizes
- Cycle counter facilitates preventive maintenance

Ordering Information

Tube OD	Ordering Number
Fractional, in.	
1/4	MS-HVSU-TLG-KIT-400-ABT
3/8	MS-HVSU-TLG-KIT-600-ABT
1/2	MS-HVSU-TLG-KIT-810-ABT
Metric, mm	
6	MS-HVSU-TLG-KIT-6M-ABT
8	MS-HVSU-TLG-KIT-8M-ABT
10	MS-HVSU-TLG-KIT-10M-ABT
12	MS-HVSU-TLG-KIT-12M-ABT

Note: Not for use with tube adapters or port connectors.

Installation Instructions for the High Volume AbT Swaging Unit may be found in the *High Volume AbT Swaging Unit User's Manual*, [MS-13-334](#).

Initial Installation Instructions

Note: Preswaging is required for all AbT connections.

Preswaging with the AbT Manual Preswaging Tool

Note: Preswaging tool should be free of contamination before use. Remove contamination with a clean, dry cloth; clean dry shop air; or nitrogen.

1. Install the Swagelok nut and ferrules onto the AbT manual preswaging tool by pushing the arbor into the preswaging tool. (Preswaging tool identified with a blue ring for fractional sizes or a yellow ring for metric sizes.)

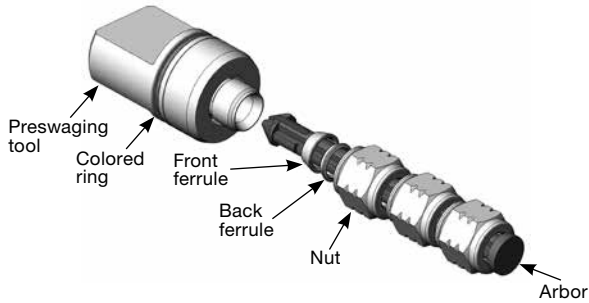

2. Rotate the nut until finger-tight, and then pull out the arbor.
3. Loosen the nut slightly, insert the tube into the AbT manual preswaging tool until it bottoms firmly into the tool. Rotate the nut until finger-tight.

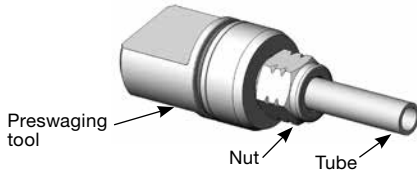

4. While holding the AbT manual preswaging tool steady (in a vise or with a wrench) and with the tube fully bottomed, tighten the nut with a wrench to the applicable torque range found in the table on this page.

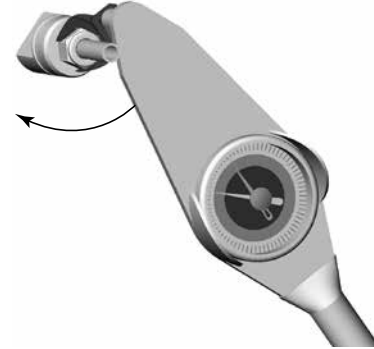

Tube Size OD × Wall	Preswaging Torque Allowable Range in.·lb (N·m)
Fractional, in.	
1/4 × 0.028	170 ± 13 (19 ± 1.5)
1/4 × 0.035	150 ± 13 (17 ± 1.5)
1/4 × 0.049	170 ± 13 (19 ± 1.5)
3/8 × 0.049	270 ± 14 (30.5 ± 1.5)
3/8 × 0.065	360 ± 18 (40.5 ± 2)
1/2 × 0.049	540 ± 27 (61 ± 3)
1/2 × 0.065	
1/2 × 0.083	660 ± 33 (74.5 ± 3.75)
Metric, mm	
6 × 1.0	150 ± 13 (17 ± 1.5)
8 × 1.0	215 ± 11 (24 ± 1.25)
8 × 1.2	
10 × 1.0	360 ± 18 (40.5 ± 2)
10 × 1.5	
12 × 1.5	660 ± 33 (74.5 ± 3.75)
12 × 1.8	

Alternate Preswaging Method

Preswaging with the use of the high-volume swaging unit (HVSU) is also acceptable. Follow the HVSU instructions provided with the unit.

5. Loosen the nut and remove the tube with the preswaged ferrules from the AbT manual preswaging tool. If the tube sticks, gently rock it back and forth. Do not turn the tube.

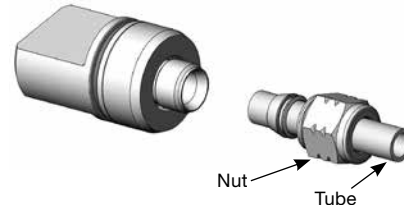

Initial Installation Instructions (cont)

Note: Preswaging is required for all AbT connections.

Tube Fitting Initial Installation Instructions

1. Insert the tube with the preswaged ferrules into the fitting body until the front ferrule seats against the body, aligning the tubing and fitting body to avoid damaging the components. Rotate the nut finger-tight.

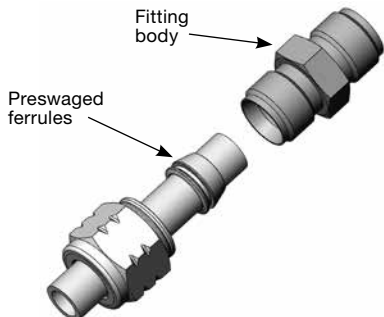

2. While holding the fitting body steady, tighten the nut (clockwise) with a wrench until the appropriate torque range for the applicable tube size is attained. See table on this page for torque ranges.

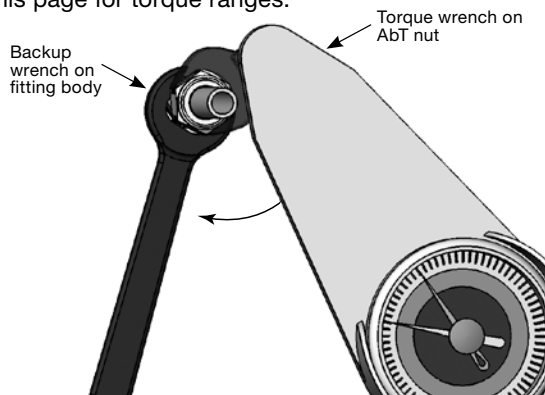

Optional Initial Installation Inspection

Visually confirm that no gap appears on the completed pull-up when the dynamic zone makes contact with the shoulder of the fitting body.

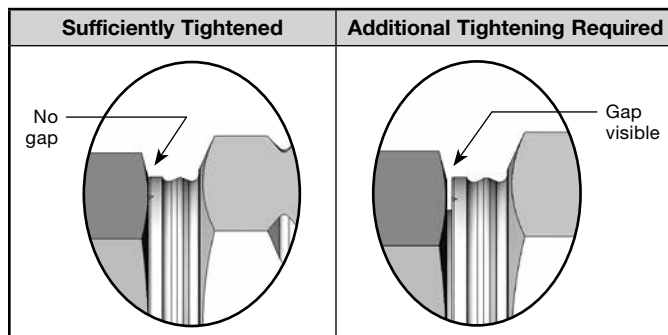

Tube Size OD × Wall	Initial Assembly Torque Allowable Range in.·lb (N·m)
Fractional, in.	
1/4 × 0.028	170 ± 13 (19 ± 1.5)
1/4 × 0.035	150 ± 13 (17 ± 1.5)
1/4 × 0.049	170 ± 13 (19 ± 1.5)
3/8 × 0.049	270 ± 14 (30.5 ± 1.5)
3/8 × 0.065	360 ± 18 (40.5 ± 2)
1/2 × 0.049	540 ± 27 (61 ± 3)
1/2 × 0.065	
1/2 × 0.083	660 ± 33 (74.5 ± 3.75)
Metric, mm	
6 × 1.0	150 ± 13 (17 ± 1.5)
8 × 1.0	215 ± 11 (24 ± 1.25)
8 × 1.2	
10 × 1.0	360 ± 18 (40.5 ± 2)
10 × 1.5	
12 × 1.5	660 ± 33 (74.5 ± 3.75)
12 × 1.8	

Proper torque is the best way to ensure a correctly installed AbT fitting.

Reassembly Installation Instructions

Reassembly

⚠ Always depressurize the system before disassembling a Swagelok AbT fitting.

1. Disassemble the tube fitting.
2. Visually inspect the fitting body and preswaged ferrules for damage and contamination. Replace damaged parts. Remove contamination with a clean, dry cloth; clean dry shop air; or nitrogen. Do not use chemicals or cleaning agents.
3. Insert the tube with preswaged ferrules into the fitting body until the front ferrule seats against the body, aligning the tubing and fitting body to avoid damaging the components. Rotate the nut finger-tight against the preswaged ferrules.

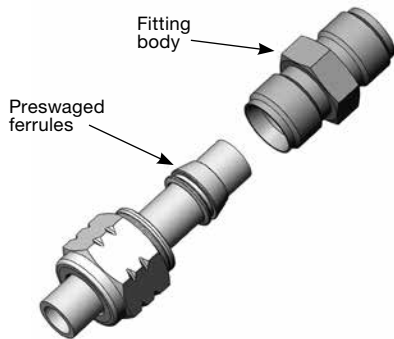

4. If using an adapter fitting, verify the adapter is installed properly prior to reassembly of the Swagelok end.

5. While holding the fitting body steady, tighten the nut (clockwise) with a wrench until the torque range is attained. See the table below for torque ranges.

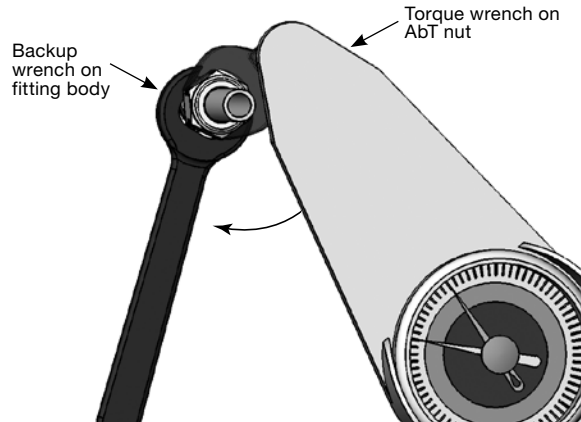

NOTE: The reassembly torque values in the table below may be higher than the initial assembly torques specified in the Tube Fitting Initial Installation Instructions found on page 10.

6. Check for visual confirmation of contact between the dynamic zone and the shoulder of the fitting body. If a gap is visible, the fitting should be tightened with a torque wrench. See the table below for torque ranges.

Note: Proper torque is the best way to ensure a correctly installed AbT fitting.

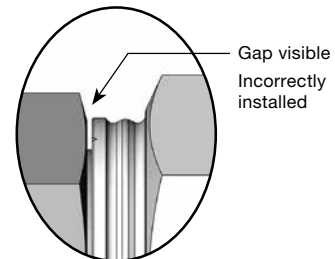

Tube Size OD × Wall	Remake Assembly Torque Allowable Range in.·lb (N·m)
Fractional, in.	
1/4 × 0.028	170 ± 13 (19 ± 1.5)
1/4 × 0.035	150 ± 13 (17 ± 1.5)
1/4 × 0.049	170 ± 13 (19 ± 1.5)
3/8 × 0.049	350 ± 17.5 (39.5 ± 2)
3/8 × 0.065	470 ± 24 (53.1 ± 2.7)
1/2 × 0.049	700 ± 35 (79 ± 4)
1/2 × 0.065	
1/2 × 0.083	800 ± 40 (90.5 ± 4.5)
Metric, mm	
6 × 1.0	150 ± 13 (17 ± 1.5)
8 × 1.0	280 ± 14 (32 ± 1.6)
8 × 1.2	
10 × 1.0	470 ± 23.5 (53 ± 2.5)
10 × 1.5	
12 × 1.5	800 ± 40 (90.5 ± 4.5)
12 × 1.8	

Safe Product Selection

When selecting a product, the total system design must be considered to ensure safe, trouble-free performance. Function, material compatibility, adequate ratings, proper installation, operation, and maintenance are the responsibilities of the system designer and user.

WARNING

Do not mix/interchange Swagelok products or components not governed by industrial design standards, including Swagelok tube fitting end connections, with those of other manufacturers.

Warranty Information

Swagelok products are backed by The Swagelok Limited Lifetime Warranty. For a copy, visit swagelok.com or contact your authorized Swagelok representative.