

See product catalog for technical data.

Contents

- Tool Requirements 1
- Mounting Hole Dimensions 2
- Components and Hardware 3
- Manifold Assembly 4
- Substrate Assembly 5
- Mounting of the MPC Assembly 6
- Surface Mount Assembly 7

Tool Requirements

- 5/32 in. hex socket driver
- O-ring pick (optional)
- Needle nose pliers (optional)

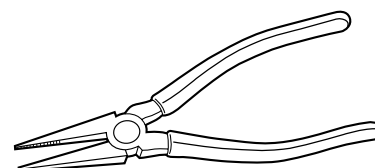
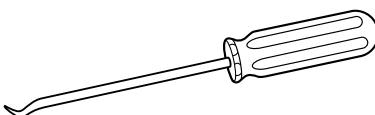
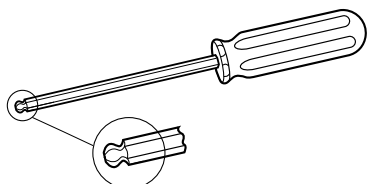

Mounting Hole Dimensions

Dimensions are shown in inches (millimeters).

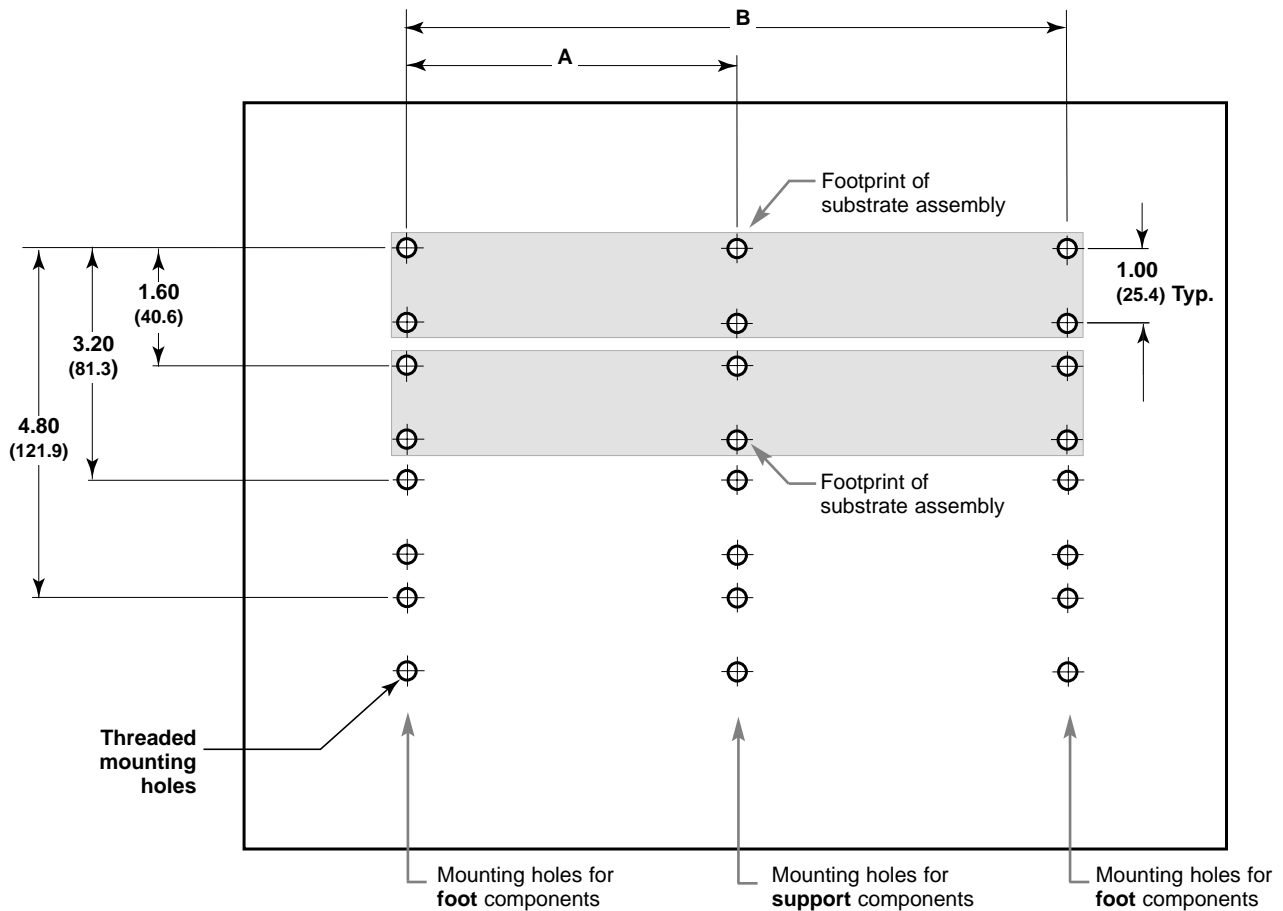

Sample Base Plate (customer supplied)

The dimensions shown above are designed for an MPC panel consisting of **four** substrate assemblies with **five** positions on each assembly.

Customized Base Plate

The following formulas can be used to determine the mounting hole locations for an MPC panel with up to 10 substrate assemblies and 14 positions on each assembly.

$$A = 1.53 \text{ in. (38.8 mm)} \times (\text{position number from the end of the base plate})$$

$$B = 1.53 \text{ in. (38.8 mm)} \times (\text{total number of positions on the substrate assembly} + 1)$$

Note:

A **support** component is recommended for use with substrate assemblies with over **four** positions to provide mid-line support.

Components and Hardware

Item Description

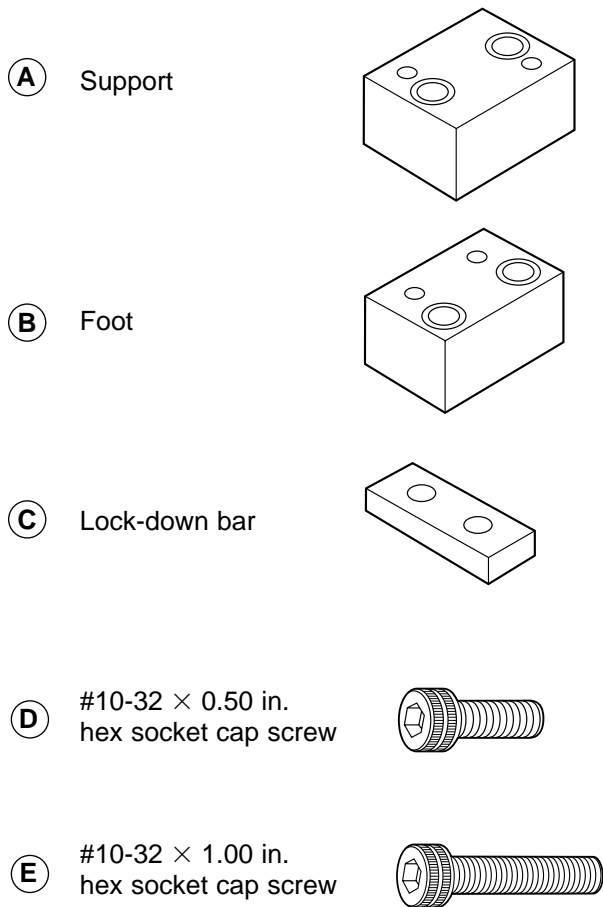

Item Description

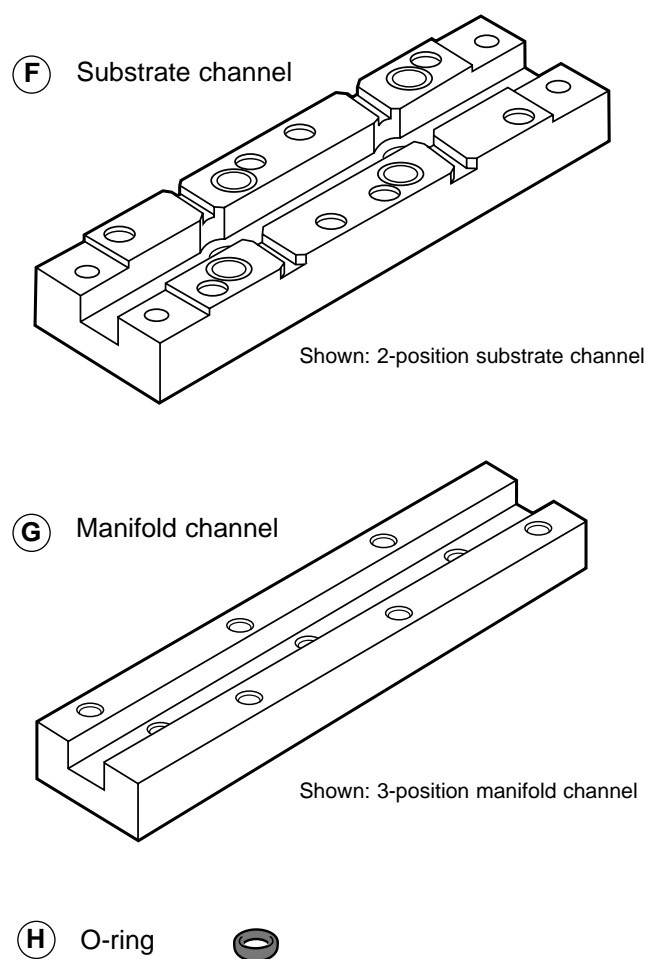

Note: Items (A) through (H) are referenced on the following pages.

Individual **substrate** and **manifold flow components**, and **surface-mount components** are not shown here due to the large variety of components available.

Torque Requirement

All #10-32 socket hex head cap screws used in the MPC assembly must be tightened to 10 in. • lb (1.13 N • m).

Manifold Assembly

1. Refer to your system layout or the assembly diagram from the MPC System Configurator to identify the proper **manifold components** and their location in the assembly.
Note: See page 3 for item (D, F, G) descriptions.
2. Place the specified **manifold flow component(s)** into the **manifold channel (G)**, aligning the **lower locating pins** in the bottom of the flow components with the **locating holes** in the channel.

3. Position the assembled **manifold channel (G)** under the **substrate channel (F)**, as specified by the system layout. Place the **upper locating pins** on the **manifold flow component** into the **drop-down hole** of the substrate channel(s).
4. Attach the **manifold channel (G)** to the **substrate channel (F)** with two **#10-32 × 0.5 in. hex socket cap screws (D)**. Torque the screws to 10 in. • lb (1.13 N • m).

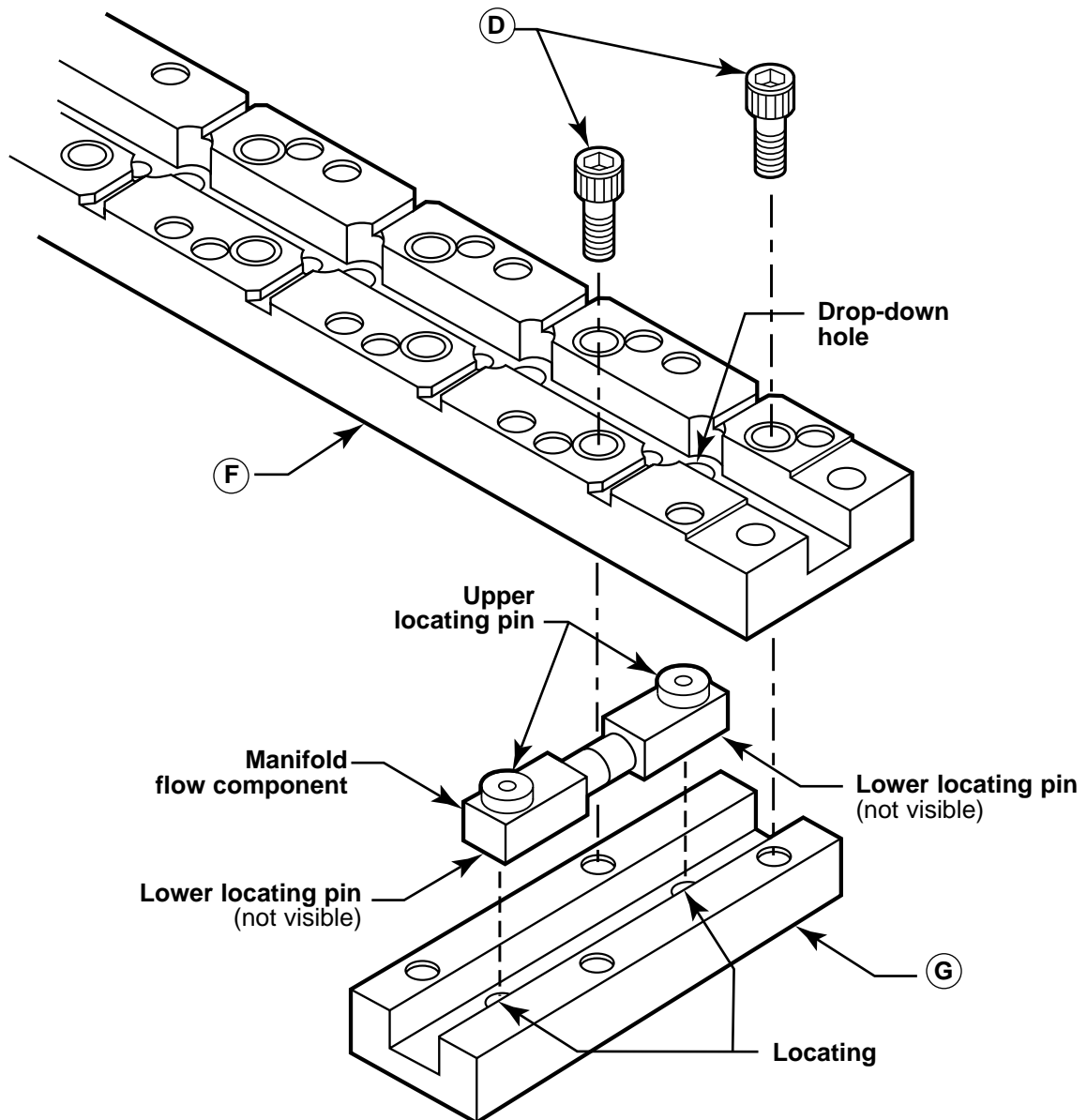

Substrate Assembly

1. Refer to your system layout or the assembly diagram from the MPC System Configurator to identify the proper **substrate components** and their location in the assembly.
2. Place an **O-ring (H)** on the bottom port of each **substrate flow component** that has a **drop-down port** to the manifold position.

Note: If a manifold position needs to be plugged, place an O-ring in the mating drop-down port in the substrate channel.

3. Place the specified **substrate flow components** into the **substrate channel (F)**, aligning the **locating pin(s)** in the bottom of the substrate flow components with **locating hole(s)** in the substrate channel.

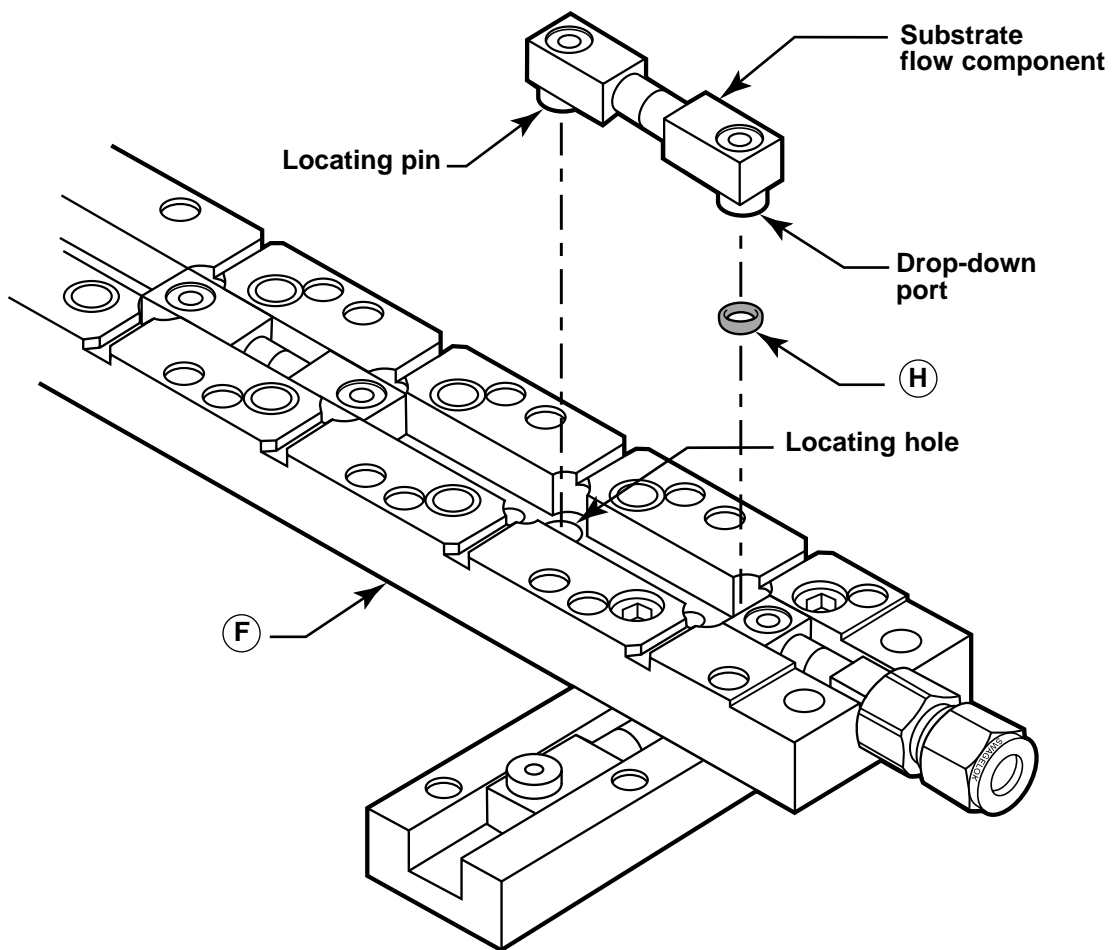

Mounting of the MPC Assembly

1. Place the **foot (B)** and **support (A)** components on the **base plate** (customer supplied) in the locations specified by the system layout. Align the **large holes** in the **foot (B)** and **support (A)** components over the mating holes in the base plate.
2. Attach and tighten each **foot (B)** and each **support (A)** component to the **base plate** with two **1/4 in. hex socket cap screws** (customer supplied).
3. Place the **substrate-manifold assembly (F)** over the **foot (B)** and **support (A)** components aligning the **mounting holes** of the **substrate-manifold assembly (F)** with the **mounting holes** of the **foot (B)** and **support (A)** components.
4. Attach the **substrate-manifold assembly (F)** to the **support (A)** component with two **#10-32 × 0.5 in. hex socket cap screws (D)**. Torque the screws to 10 in. • lb (1.13 N • m).
5. Place a **lock-down bar (C)** over the **mounting holes** at each end of the **substrate-manifold assembly (F)**. Attach each **lock-down bar (C)** and **substrate manifold (F)** to the **foot (B)** with two **#10-32 × 1.0 in. hex socket cap screws (E)**. Torque the screws to 10 in. • lb (1.13 N • m).

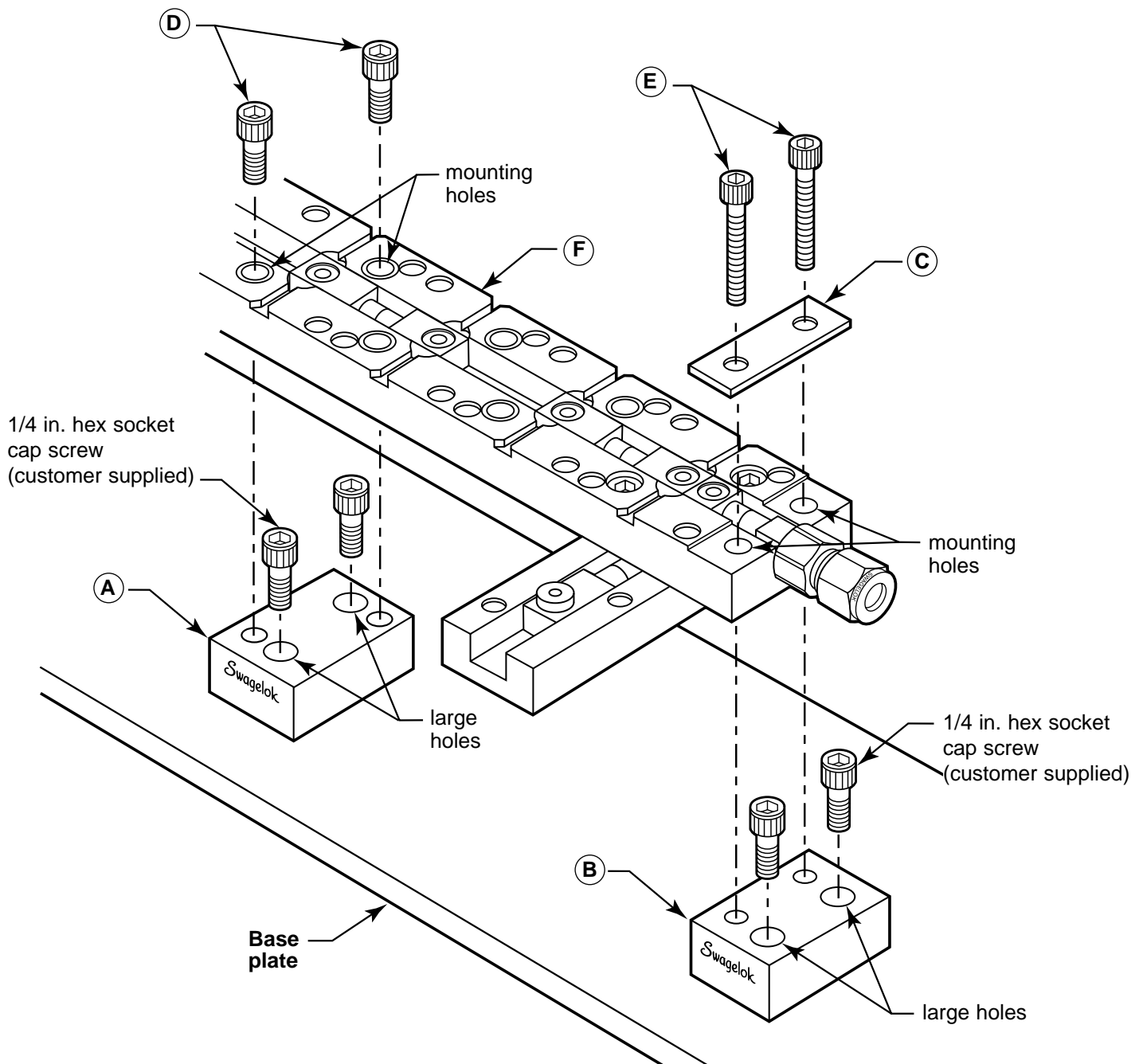

Surface Mount Assembly

1. Refer to your system layout or the assembly diagram from the MPC System Configurator to identify the proper **surface-mount components** and **O-rings**, and their location in the assembly.
2. Place an **O-ring (H)** on the **top port** of every **substrate flow component(s)** in the channel.
3. Place each **surface-mount component** over the proper position on the **substrate assembly (F)**. Align the bottom ports (not visible) in the **surface-mount component** with the **top ports** in the **substrate flow components**, and align the four **mounting holes** in the **surface-mount component** with the four **threaded holes** in the **substrate channel (F)**.
4. Attach each **surface-mount component** to the substrate channel with four **#10-32 × 0.5 in. hex socket cap screws (D)**. Torque the screws to 10 in. • lb (1.13 N • m).
5. Test the complete assembly for leak-tight integrity and proper operation.

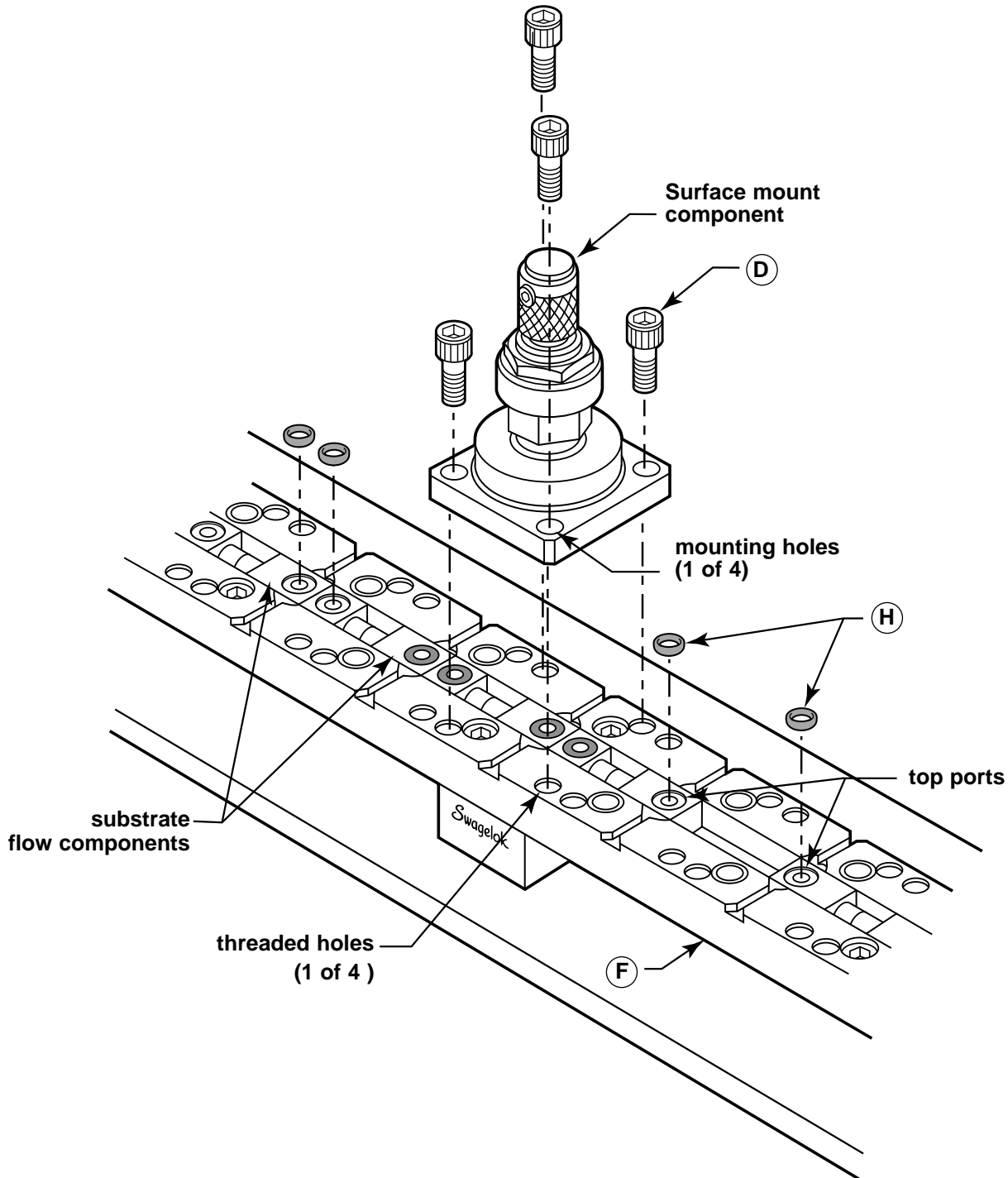

Safe Product Selection

When selecting a product, the total system design must be considered to ensure safe, trouble-free performance. Function, material compatibility, adequate ratings, proper installation, operation, and maintenance are the responsibilities of the system designer and user.

MPC, Swagelok — TM Swagelok Company
© 2002 Swagelok Company
Printed in the U.S.A.
December 2002
MS-12-39
