

**Swagelok® Process Regulators
Pressure Reducing 1/2 in. to 1 1/2 in. User Manual**



Read the complete manual before installing and using the regulator.

Safe Product Selection

When selecting a product, the total system design must be considered to ensure safe, trouble-free performance. Function, material compatibility, adequate ratings, proper installation, operation, and maintenance are the responsibilities of the system designer and user.



WARNING

- Users must be trained and equipped for the handling, use, and servicing of pressure products and systems.
- Users must contact their gas or liquid supplier for specific safety precautions and instructions.
- Gaseous media should be free of excessive moisture to prevent icing at high flow.
- Always wear the appropriate protective clothing, including safety glasses, gloves, etc., if required.
- Follow the applicable safety and maintenance procedures.
- Obey specific local regulations.
- Do not exceed the maximum inlet and outlet pressure rating of the product or its accessories.
- Operate within the temperature limits and any other conditions specified for the product.
- Do not drop or damage the product in any other way. This may negatively affect the performance of the product which can cause the product to malfunction.

Contents

Series Overview	4
Standard Features.....	5
Additional Options	5
Oxygen Service	5
Installation.....	6
Points of Attention Before Installation.....	6
Installation	6
Operation	7
Points of Attention Before Operation	7
Adjusting the Set Pressure.....	7
Antitamper Handle Operation	7
Dome Pressure Control.....	8
Maintenance	13
Required Tools for Maintenance	13
Points of Attention Before Removal from the System	14
Removal from the System.....	14
Assembly Reference Data.....	15
Diaphragm Sensing, Section View	17
Piston Sensing, Section View	18
Diaphragm Sensing, Self-Vent, Section View	19
Diaphragm Sensing, Captured Vent, Section View.....	19
Piston Sensing, Self-Vent, Section View.....	20
Piston Sensing, Captured Vent, Section View	20
Ratio Sensing Mechanism, Self-Vent, Section View	21
Assembly and Disassembly.....	22
Points of Attention Before Reassembly	22
Instruction symbols.....	22
Step 1: Assemble Body Insert	23
Step 2: Assemble Poppet	24
Step 3: Assemble Body Plug, Poppet Assembly, and Seat.....	25
Step 4a: Assemble Diaphragm	26
Step 4b: Assemble Piston.....	27
Step 5 (optional): Assemble Self-Vent Seat	28
Step 6 (optional): Assemble Vent Plate	29
Step 7 (optional): Assemble Ratio Dish.....	30
Step 8 (optional): Assemble Spring Housing	31
Step 9: Assemble Spring Housing/Dome onto Body.....	32
Step 10a (optional): Assemble Standard Handle	33
Step 10b (optional): Assemble Antitamper Handle.....	34
Step 11: Assemble Pilot Regulator	35
Testing	36
Seat Leak Test.....	36
Shell Leak Test	36
Regulator Tuning	38
Troubleshooting.....	39

Series Overview

This user manual covers the following regulator series:

	Spring-Loaded	Dome-Loaded	Air-Loaded Ratio	Electronic Control
General Industrial	SGRS	SGRD	SGRA	SGRE
High Sensitivity	SHRS	SHRD	–	–

Regulator Size

This instruction manual covers the following sizes of regulators:

- 08 (1/2 in.)
- 12 (3/4 in.)
- 16 (1 in.)
- 24 (1 1/2 in.)

For pressure and temperature rating information refer to the *Process Pressure Regulators* catalog, [MS-02-492](#). Note that seat seal material selection can limit the regulator operational pressure at elevated temperatures.



WARNING

Check that system pressures and temperatures do not exceed those stated on the regulator as this could result in product failure.

Standard Features

- Modular design
- Bolted construction
- Stainless steel as standard
- Fully serviceable
- Diaphragm or piston sensing
- Balanced poppet

Additional Options

Process regulators are available with the following options. Some options are only available on specific regulator series.

- Standard handle or antitamper handle
- Gauge port configurations
- Non-venting, self-venting or captured venting
- Standard pilot, external feedback to pilot or differential pressure pilot
- Additional testing
- Panel mounting kits
- Maintenance kits



WARNING

The self-venting feature is for venting off excessive outlet pressure under zero flow conditions. It is not intended to be used as a safety relief device.

Oxygen Service

- For more information about hazards and risks of oxygen enriched systems see the Swagelok *Oxygen System Safety* technical report, [MS-06-13](#).
- Cleaning and packaging in accordance with Swagelok *Special Cleaning and Packaging (SC-11)* catalog, [MS-06-63](#), to ensure compliance with product cleanliness requirements stated in ASTM G93 Level C is available. Refer to the *Process Pressure Regulators* catalog, [MS-02-492](#), for additional information.

Installation



CAUTION

Do not use the regulator as a shutoff device. A level of leakage across the regulator seat can occur during normal operation.

Points of Attention Before Installation

This regulator can be equipped with a variety of different options. Before installing the regulator, you should fully understand the functions of the supplied options and the suitability of your particular regulator for the intended application.

- The preferred mounting position of the regulator is horizontal with the spring housing/dome facing upwards according to Figure 1 (See [page 9](#)). Alternative mounting positions may increase the risk of component wear.
- It may be necessary to remove the regulator from the system during maintenance or service. Ensure that this is possible.
- The regulator is suitable for gases or liquids. Ensure compatibility between the regulator's materials of construction and the system media.
- Swagelok recommends the use of a non-venting regulator when the process media is hazardous or toxic.

Installation

- Verify that the regulator, its connections, and any accessories are undamaged.
- Verify that the regulator and any accessories are suitable for the system operating pressure and temperature and have suitable connections.
- At the time of delivery some auxiliary ports may be plugged. Remove these plugs and connect accessories if desired.
- If inlet/outlet fittings are being used, assemble them to the regulator, according to the manufacturer's instructions, prior to installing the regulator in the system.



CAUTION

Ensure all upstream tubing/pipework is clean and free from debris. Any swarf, lint, wire, etc., may damage the regulator, resulting in a seat leak.

- Verify the flow direction of the system and mount the regulator accordingly.
- Regulators can be panel mounted using a panel mounting kit.
- Securely make the appropriate connections to the regulator in accordance with the procedures recommended by the connection manufacturer.
- Ensure that the tubing/pipework and the regulator are adequately supported and that there is no stress on the connections.
- Upstream and downstream shutoff valves should be installed in the system to facilitate servicing, maintenance, and troubleshooting of the regulator.



CAUTION

Do not plug the auxiliary port in the vent plate, if present. Vented pressure would become trapped in the regulator. This would alter the regulator set pressure and any trapped pressure could be released upon disassembly. The port must be open to atmosphere either directly or via a vent line.

Operation

Points of Attention Before Operation



CAUTION

The product can be hot or cold, depending on the environmental temperature and the process media temperature. Take the necessary precautions before operating or touching the product.

- Stopping flow through the regulator by closing a downstream shutoff valve may result in a rise in outlet pressure above the set pressure. This is usually referred to as “lock-up.” This phenomenon does not indicate a problem with the regulator.
- A decrease of the flow rate may result in a rise of the outlet pressure. An increase of the flow rate may result in a fall of the outlet pressure. This is usually referred to as “droop.” This phenomenon does not indicate a problem with the regulator.
- A decrease of the inlet pressure may result in a rise of the outlet pressure. An increase of the inlet pressure may result in a fall of the outlet pressure. This is usually referred to as “inlet dependency” or “Supply Pressure Effect (SPE).” This phenomenon does not indicate a problem with the regulator.

Adjusting the Set Pressure

- The set pressure is the desired outlet pressure of the regulator.
 - To set the regulator, ensure that the supply pressure is greater than the required set pressure but does not exceed the maximum rating of the regulator.
 - If the regulator is non-venting it must be able to flow in order for it to reduce the outlet pressure.
1. For non-venting regulators partially open any downstream valve. This will allow minimal flow through the regulator when adjusting the set pressure, reducing media consumption during this process.
 2. Fully unwind the adjustment knob counterclockwise or reduce dome pressure to zero.
 3. Steadily open the supply valve fully to allow inlet pressure to the regulator.
 4. To operate the regulator, turn the adjustment knob clockwise or increase the dome pressure to increase the set pressure. Turn the knob counterclockwise or reduce the dome pressure to reduce the set pressure.
 5. To obtain the most accurate set pressure, final adjustment must be made while increasing the set pressure. If the desired outlet pressure is exceeded, reduce the pressure below this value then increase up to it.
 6. Fully open the downstream valve to allow full flow during operation.
 7. Once under flow conditions make any necessary set pressure adjustments according to steps 4 and 5.

Antitamper Handle Operation

The antitamper handle is intended to prevent accidental or unwanted adjustment of the regulator. The handle can be set in two positions.

- With the handle fully depressed it will drive the stem and adjust the set pressure in the same manner as a standard handle.
- With the handle pulled out it will no longer drive the stem and will be free spinning. In this position two holes are presented which can be used in conjunction with a padlock or similar device to lock out the regulator if desired.

Dome Pressure Control

For dome loaded regulators the dome pressure of the regulator controls the set pressure. There are several methods available for supplying and controlling the dome pressure.

- **Integral pilot control.** In this setup the dome loaded regulator comes supplied with a pilot regulator as part of the assembly (Figure 1). The pilot regulator, fed from the system pressure, is manually operated to control the dome pressure (Figure 2). This setup is not suitable for liquid applications
- **External feedback to pilot control.** In this setup an external feedback line can be connected from the regulator outlet line to the integral pilot regulator (Figure 3). This will allow for more accurate and stable pressure regulation and improved droop performance. Ideally the external feedback line is to be connected into a turbulence-free zone in the downstream piping and kept as short as practicable. The distance between the regulator outlet and the external feedback line connection can affect the regulator response time. This distance should be kept to a minimum.



CAUTION

When using a regulator with external feedback, ensure that the outlet line is connected to the external feedback port before applying pressure to the regulator. Failing to do so may lead to damage and non-functioning of the regulator and no pressure regulation will occur.



CAUTION

Never connect the external feedback line downstream of a shut-off valve. Doing so may lead to damage and non-functioning of the regulator and no pressure regulation will occur.

- **Differential pressure pilot control.** In this setup a reference pressure line can be connected to the integral pilot regulator (Figure 4). The pilot regulator can then be adjusted to set a bias pressure. The main regulator will then be set to an outlet pressure equal to the reference pressure plus the bias pressure.
- **External dome control.** In this setup the dome pressure is supplied from an independent source, such as a cylinder or mains supply (Figure 5). This setup is suitable for liquid applications.
- **Electronic control.** In this setup an electronic pilot regulator, fed from the system pressure, is used in conjunction with a pressure transducer to directly control the dome pressure (Figure 6). The outlet pressure of the main regulator will be limited by the outlet pressure of the electronic regulator. This setup is not suitable for liquid applications.
- **Ratio control.** In this setup a ratio pilot regulator, fed from the system pressure, is used to control the dome pressure. The ratio pilot can be controlled by an electronic regulator and pressure transducer combination (Figure 7) or by an external dome feed. The ratio pilot outlet pressure is proportionally larger than its dome pressure. This enables the main regulator to achieve full outlet pressure while being controlled from a low-pressure supply. This setup is not suitable for liquid applications.

The best performance will be achieved by allowing a small flow to continuously pass through the pilot regulator. This flow can either be vented through an orifice (Figure 5) or, in gas systems, fed back through an orifice into the downstream piping (Figure 2). This is usually referred to as **dynamic regulation**. If dynamic regulation is not desirable a self-venting pilot regulator would be required. This would result in system media being vented to atmosphere when decreasing the regulator set pressure.



NOTICE

It is not recommended to place a gauge on the dome to set or check the outlet pressure. Because of forces in the regulator, the dome pressure will differ slightly from the outlet pressure. Place a gauge in the outlet line to set or check the set pressure.

Integral Pilot Assembly

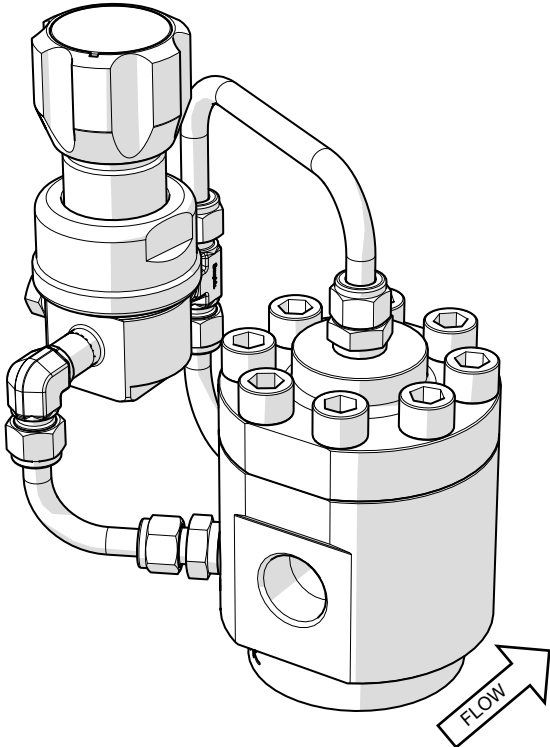

Figure 1

Integral Pilot Control Schematic

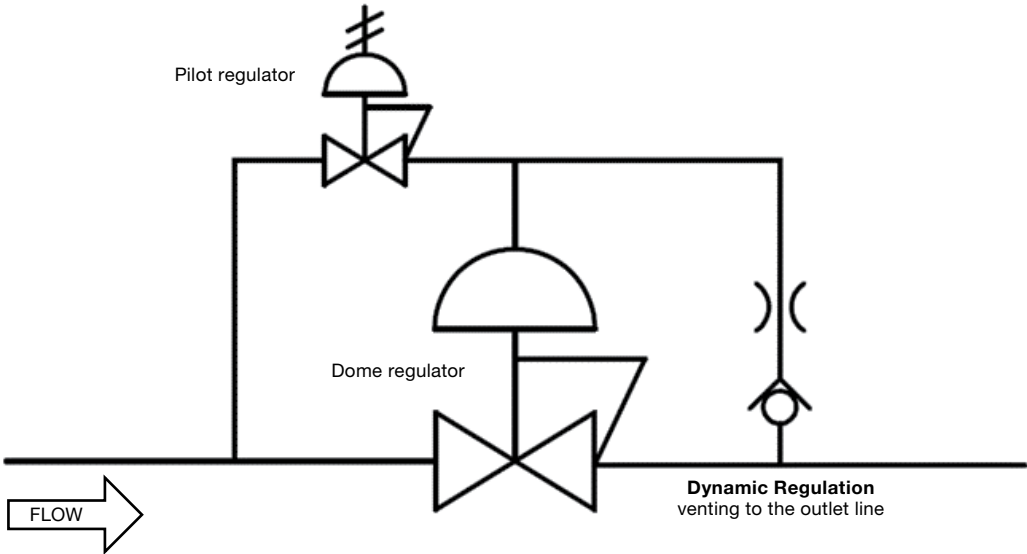

Figure 2

External Feedback to Pilot Control Schematic

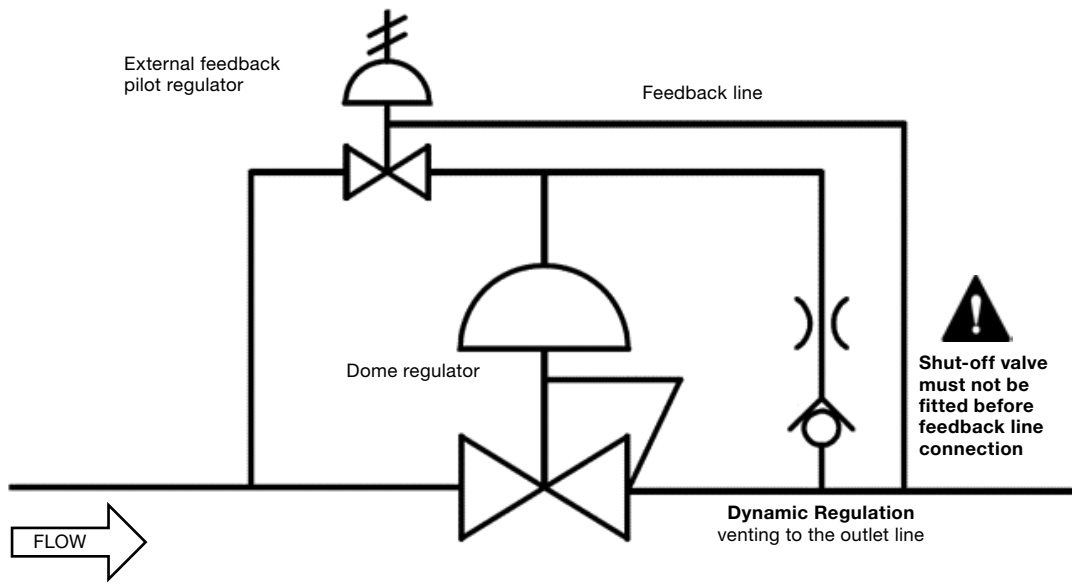

Figure 3

Differential Pressure Pilot Control Schematic

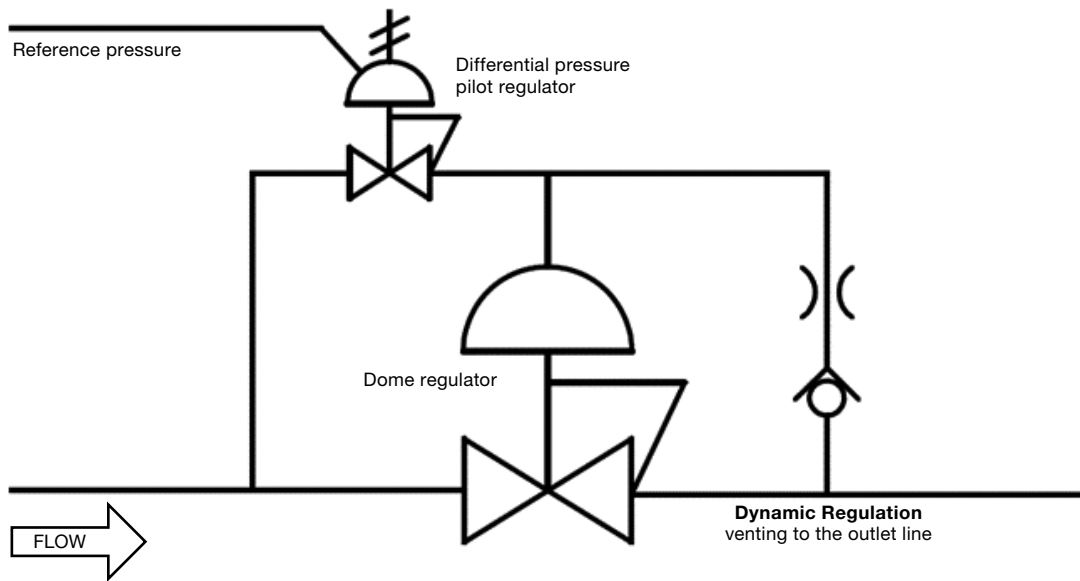

Figure 4

External Dome Control Schematic

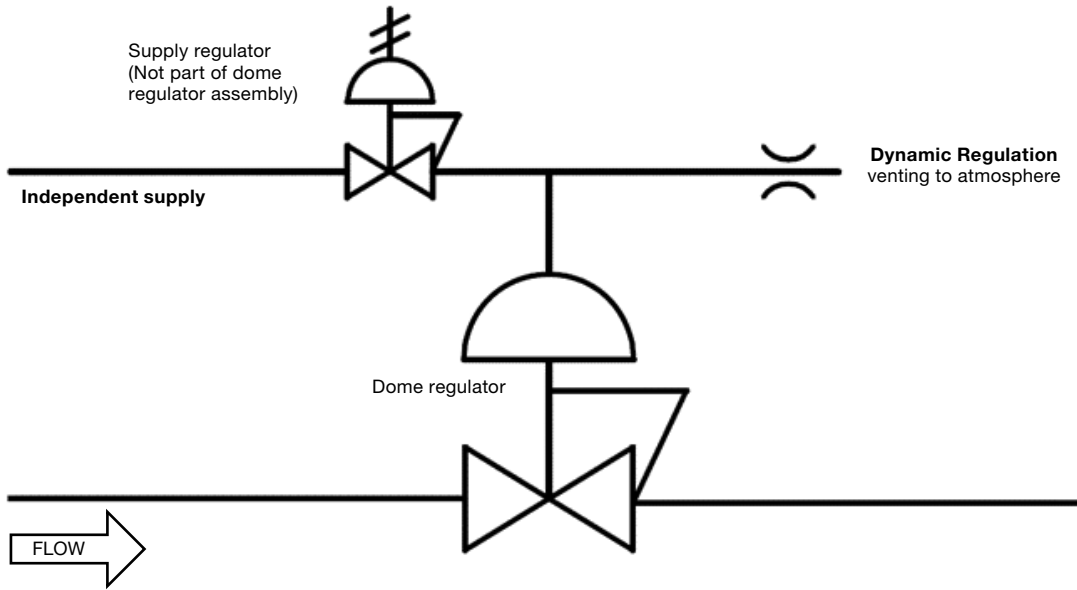

Figure 5

Electronic Control Schematic

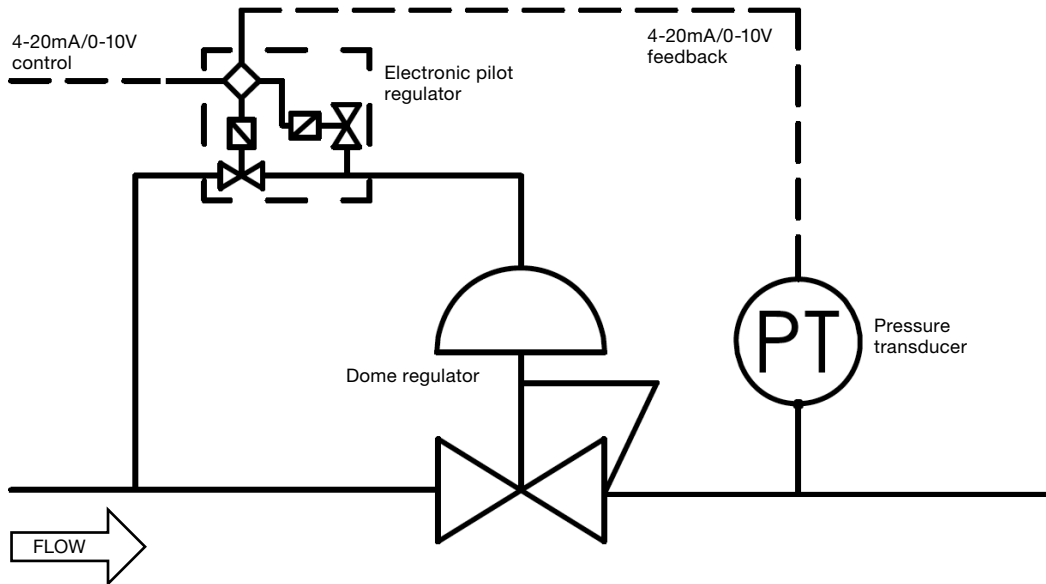

Figure 6

Ratio Control Schematic – Electronic Pilot

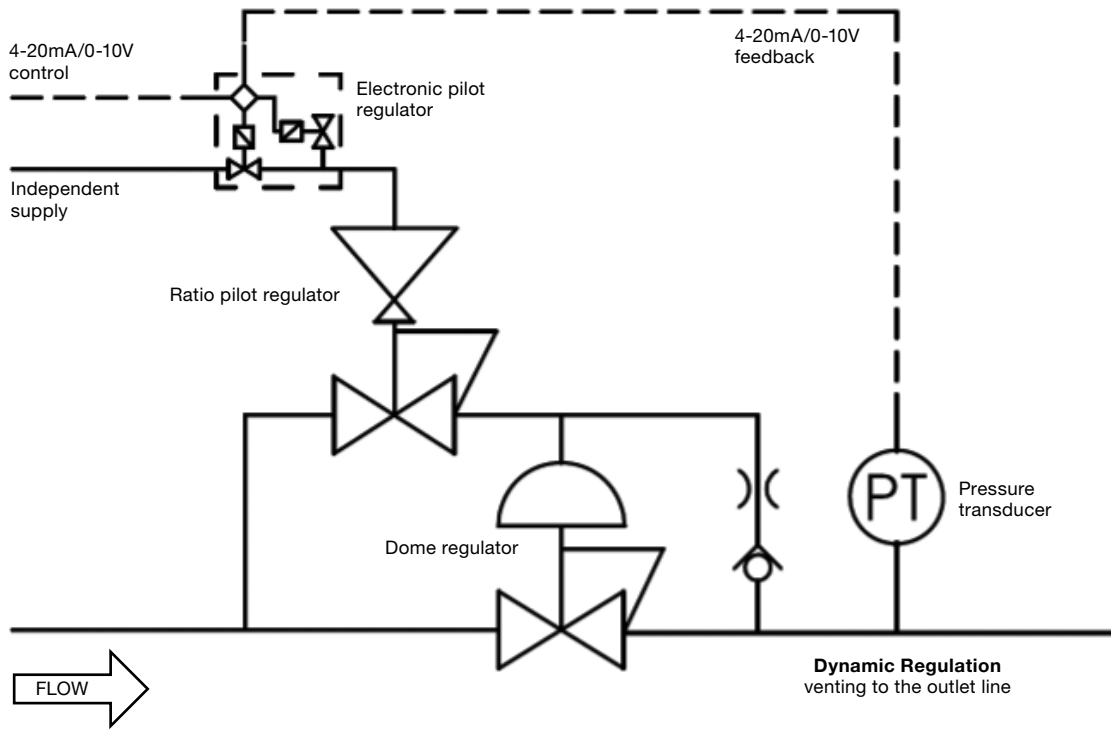

Figure 7

Maintenance









WARNING

Incorrect or improper repair or servicing of this product can cause serious personal injury and property damage.

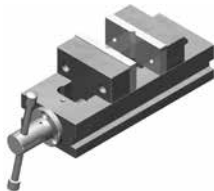
- All repairs, servicing, and testing of this product must be performed by competent personnel.
- Following any maintenance of the regulator, it is recommended that the product be tested for operation and leakage.
- The product should be checked periodically for proper and safe operation. It is the user's sole responsibility to determine the frequency of maintenance based on the application.
- To reduce maintenance related system downtime to a minimum, either during commissioning or normal operation, Swagelok recommends having maintenance kits readily available on site. The need for maintenance kits is particularly important during the commissioning phase of a system installation due to residual assembly debris remaining in the system. Such debris can cause a seat leak in the regulator, resulting in components needing to be replaced.
- For servicing of pilot regulators please see the applicable user manual for that series of regulator.

For more information on Swagelok process regulator maintenance kits, refer to the *Process Pressure Regulators* catalog, [MS-02-492](#).

Required Tools for Maintenance

Smooth-jawed vise		Calibrated torque wrench up to 89 ft·lb (120 N·m)	
13 mm socket		Lubricant (included in kit) WL-8 ^① Krytox 240 [®] AC ^②	
24 mm socket			
30 mm socket			
3 mm hex drive		Liquid leak detector	
5 mm hex drive			
10 mm hex drive			
14 mm hex drive			

① Standard cleaned assemblies

② SC-11 cleaned assemblies

Points of Attention Before Removal from the System

- Swagelok recommends removing the regulator from the system for servicing and maintenance.
- Follow all local system safety and maintenance procedures when removing the regulator.



WARNING

Before removing a regulator from the system, to avoid personal injury, you must:

- Depressurize the system.
- Purge the system to remove any residual system media left in the regulator.
- Always vent to a safe environment away from people and ensure there is adequate ventilation.



CAUTION

Check if the process media is hazardous or toxic. If required, take the necessary safety precautions to ensure a safe workspace and your personal safety.



CAUTION

The product can be hot or cold, depending on the environmental temperature and the process media temperature. Take the necessary precautions before operating or touching the product.

Removal from the System

1. Isolate the regulator from all pressure sources by closing all appropriate upstream valves in the system.
2. With the regulator set, open all appropriate downstream valves to allow pressure to vent from the regulator. (i.e. The adjustment knob is rotated clockwise enough to allow flow through the regulator.)



WARNING

Ensure all pressure on the inlet, outlet and dome has been fully vented. The accidental release of residual trapped pressure can cause serious personal injury.

3. Ensure any appropriate lifting equipment is available to enable the regulator to be supported and handled once disconnected from the system.
4. Ensure that any external dome feed is disconnected.
5. Disconnect and remove the regulator from the system.

Assembly Reference Data

		Nominal torque by product size, ft·lb (N·m)			
Item	Component Name	08, 12	16	24	Lubrication
1	Logo ring				
2	Body plug	30 (40)	37 (50)	52 (70)	Wt
4	Body				
5	Poppet				Wt
7	Poppet backup ring				
8	Poppet O-ring				Wt
9	Poppet E-clip				
10	Body plug backup ring				
11	Body plug O-ring				Wt
12	Poppet spring				
13	Seat assembly				
14	Seat housing				
15	LP seat insert				
16	LP seat insert O-ring				
17	Seat O-ring				
20	Body insert lower				
21	Body insert O-ring				Wt
22	Body insert upper	15 (20)	30 (40)	30 (40)	Wt
23	Self-vent seat				
24	Self-vent seat O-ring				Wt
25	Diaphragm screw				Wt
26	Diaphragm plate lower				
27	Diaphragm				
28	Diaphragm plate upper				
29	Diaphragm Nut	30 (40)	30 (40)	30 (40)	
30	Piston				Wt
31	Piston plate				
32	Piston body O-ring				
33	Piston O-ring				Wt
34	Piston backup ring				
35	Vent plate				
36	Vent plate shaft O-ring				Wt
37	Vent plate body O-ring				
38	Ratio plate				

Item	Component Name	Nominal torque by product size, ft·lb (N·m)			
		08, 12	16	24	Lubrication
44	Spring damper				
45	Spring housing				
46	Screws – cap	37 (50)	89 (120)	89 (120)	Wt
47	Dome				
48	Lower spring button				Wt
49	Range spring				
50	Stem				Bk
51	Upper spring button				Bk
52	Slot cover				
53	Button screw	1.5 (2)	1.5 (2)	1.5 (2)	Wt
54	Thrust washer				Bk
55	Knob				
56	Disk spring				
57	Stem washer				
58	Stem screw	3.7 (5)	3.7 (5)	3.7 (5)	Wt
59	Knob cover				
60	Antitamper inner				
61	Antitamper outer				
62	Antitamper cap				Wt
63	Antitamper circlip				
64	Screws – high sensitivity cap	3.7 (5)	3.7 (5)	3.7 (5)	Wt
65	Antitamper pin				
70	BSP fittings	26 (35)	26 (35)	26 (35)	Wt
71	BSP seals				
72	Tube				
73	Pilot regulator				
74	Check valve spring				
75	Check valve guide				
76	Check valve seat				
77	Check valve fitting	26 (35)	26 (35)	26 (35)	Wt
78a	NPT plug	15 (20)			Wt
78b	BSP plug	26 (35)	26 (35)	26 (35)	Wt

Diaphragm Sensing, Section View

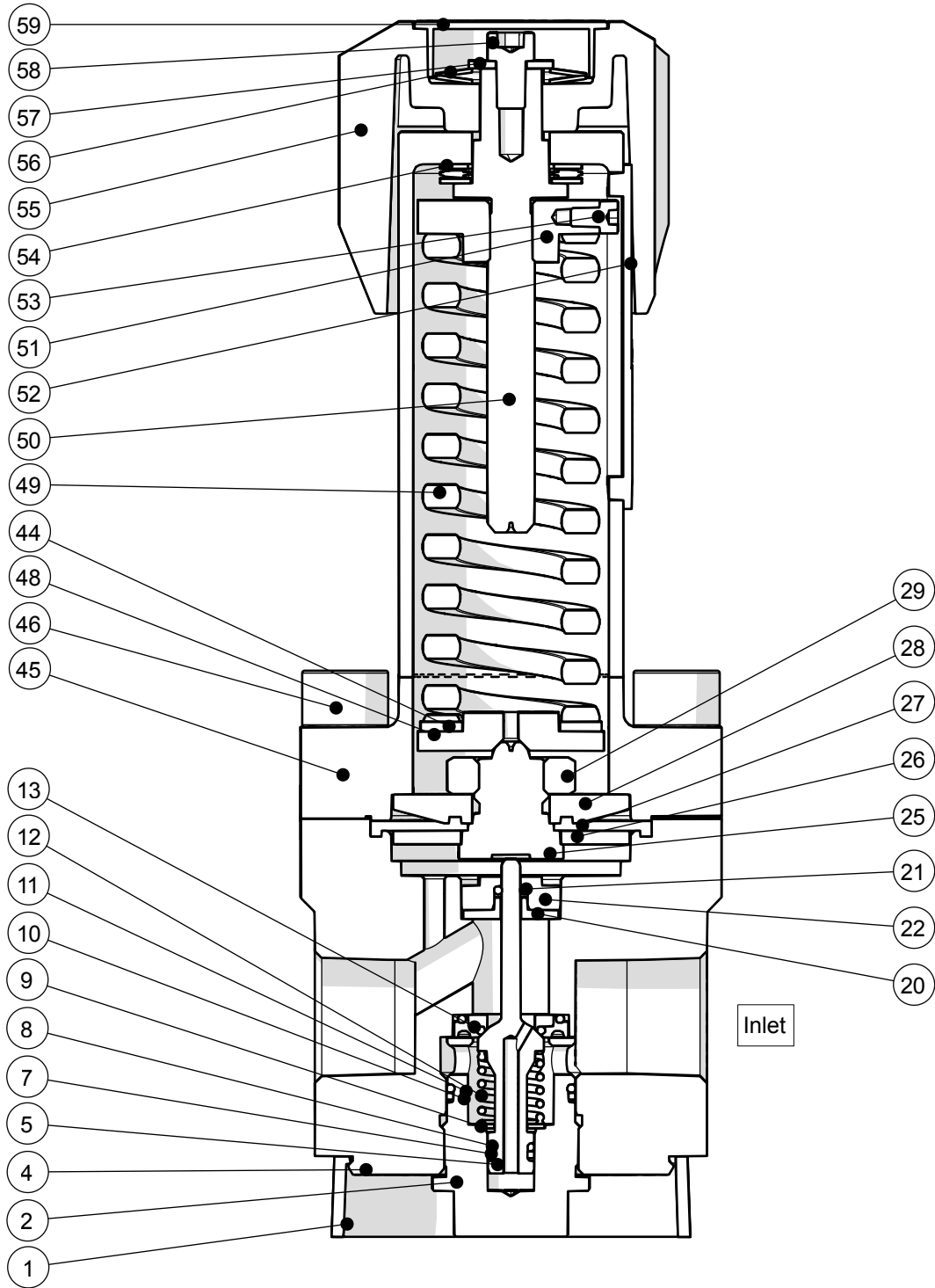

Figure 8

Piston Sensing, Section View

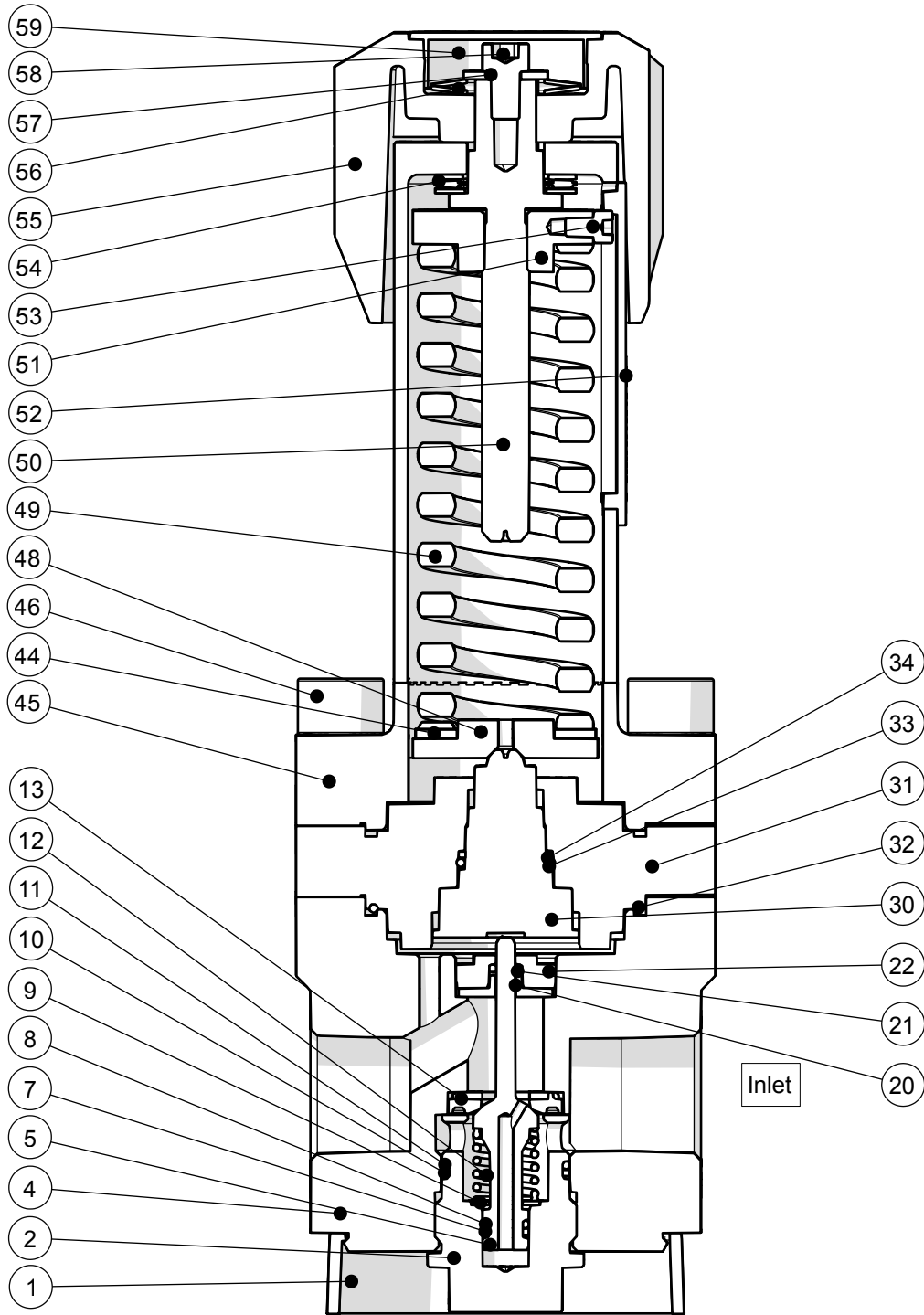

Figure 9

Diaphragm Sensing, Self-Vent, Section View

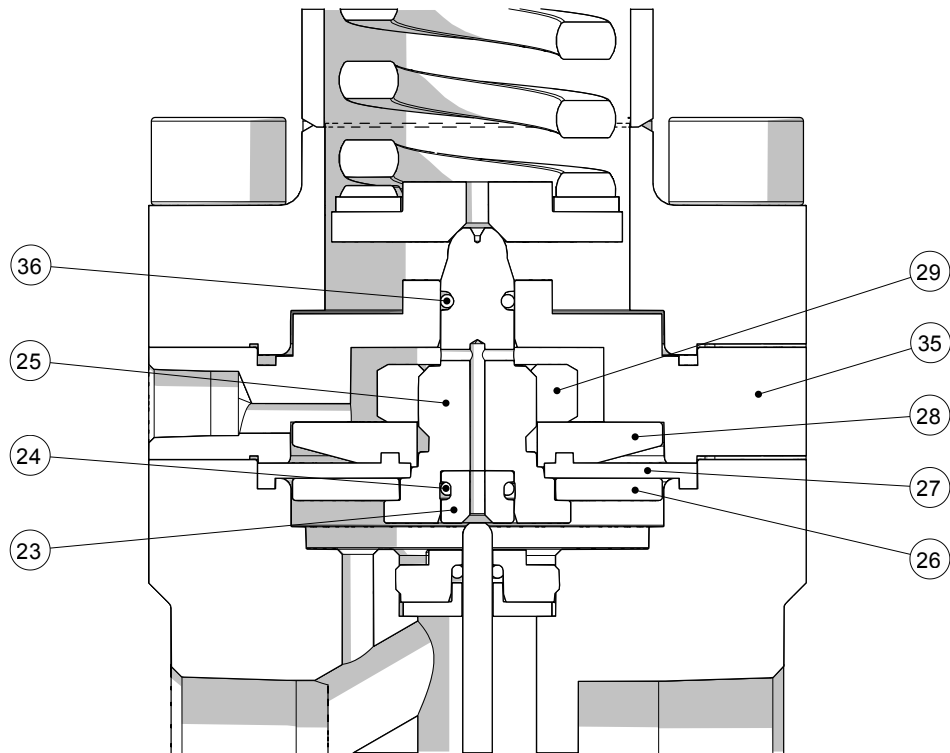

Figure 10

Diaphragm Sensing, Captured Vent, Section View

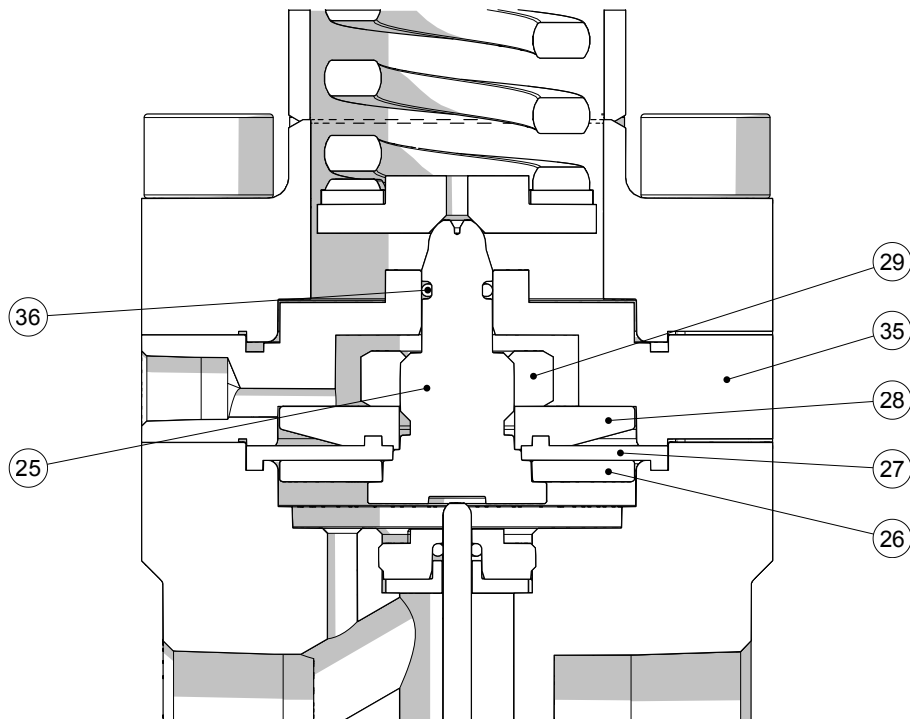

Figure 10a

Piston Sensing, Self-Vent, Section View

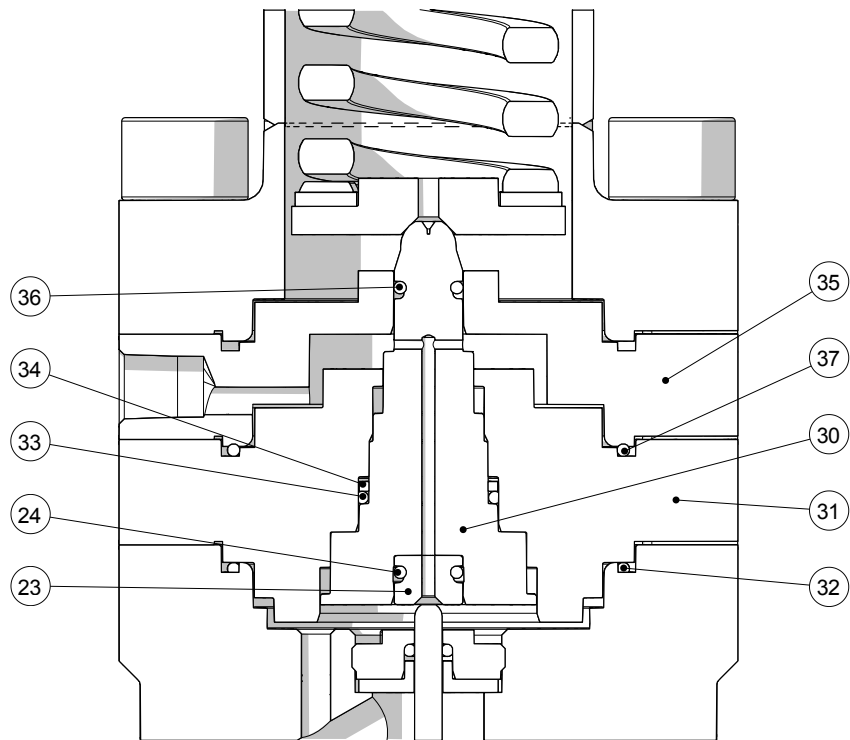

Figure 11

Piston Sensing, Captured Vent, Section View

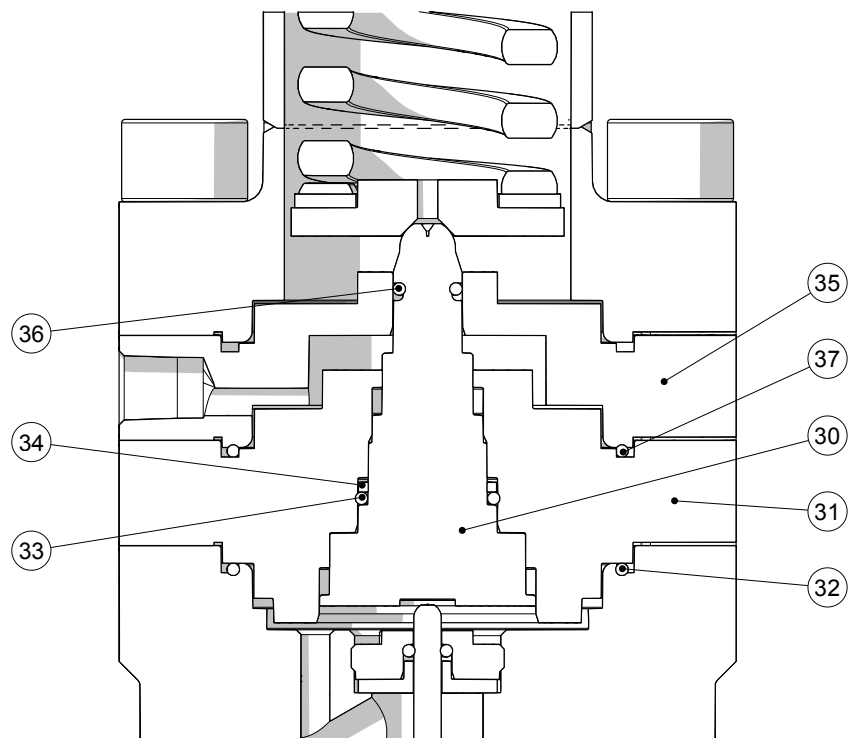

Figure 11a

Ratio Sensing Mechanism, Self-Vent, Section View

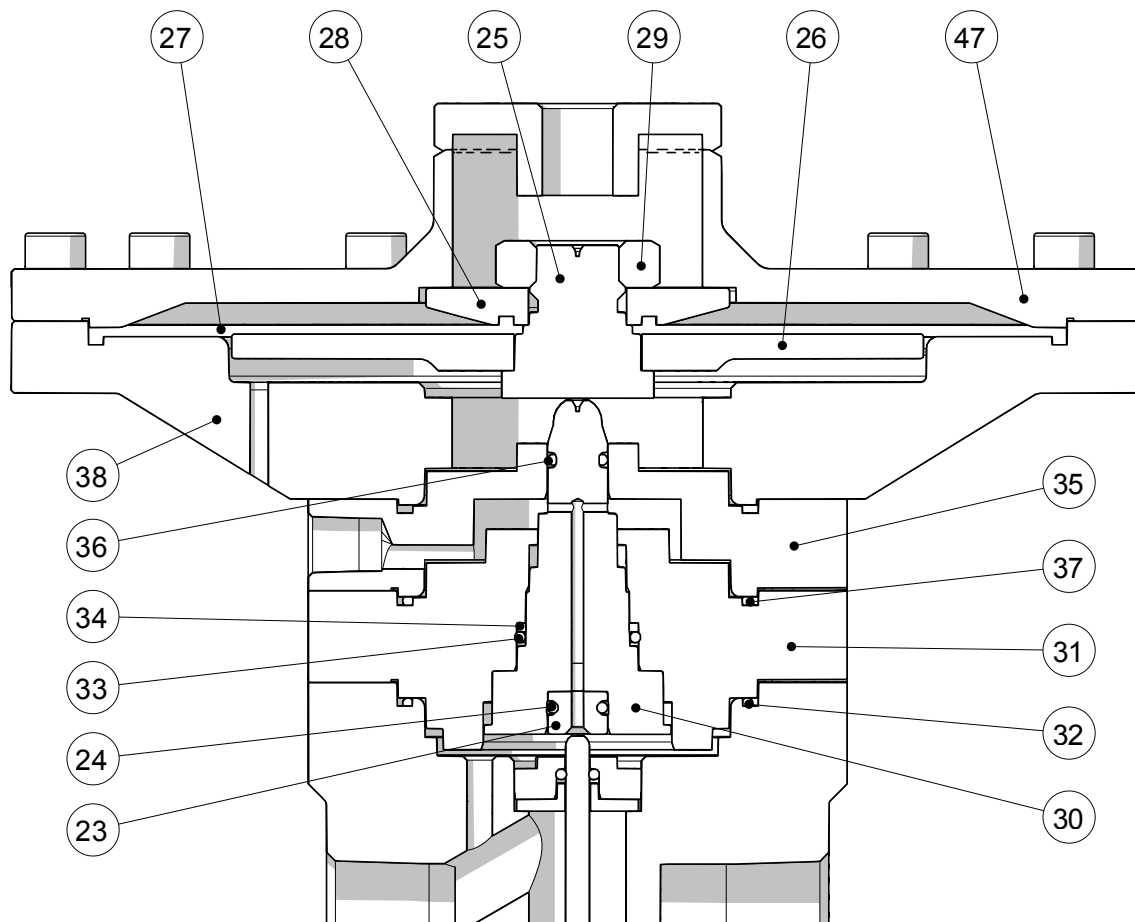

Figure 12

Assembly and Disassembly

- For the purposes of maintenance and repair the following instructions describe how to fully assemble a pressure reducing regulator. For disassembly follow the instructions in reverse order.
- Note that the components shown in this instruction manual may differ visually to those in the regulator.
- Note that not all components shown appear in all regulator configurations.
- Only disassemble the regulator as far as is required to replace the components supplied in the maintenance kit.
- Discard all components being replaced.

Points of Attention Before Reassembly

- Visually inspect all components for abnormal wear or damage. Replace components in case of doubt.
- All parts must remain clean and undamaged before starting assembly.
- Maintenance kit components will be supplied preassembled where practicable to aid reassembly.
- Swagelok recommends replacing all O-rings removed during disassembly.
- Swagelok recommends that dynamic O-rings should be lightly lubricated according to **Assembly Reference Data** table on page 15.



NOTICE

All threaded components must be lightly lubricated according to the Assembly Reference Data table on page 15 before reassembly to avoid galling of threads.

Instruction symbols

Lubricate component = 

Torque = 

WT = PTFE based grease, Swagelok WL-8 or comparable. (or Krytox 240AC for SC-11 cleaned units)

BK = Graphite-based grease, Swagelok WL-7 or comparable.

Where multiple bolts require torquing, a crisscross sequence should be used as shown below.

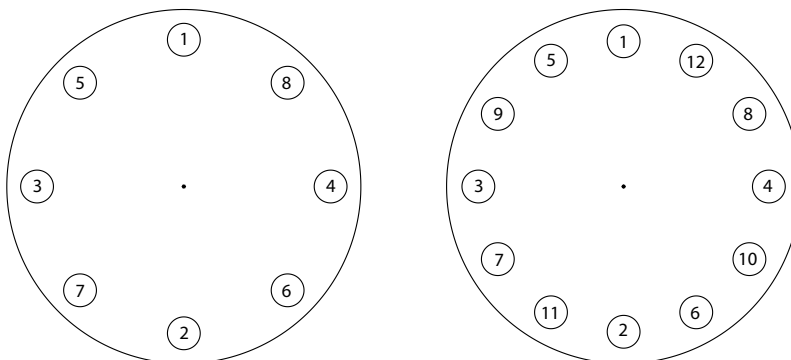

Step 1: Assemble Body Insert

See Figure 13.

1. Secure the body (4) in a vise.
2. Fit the body insert O-ring (21) and body insert lower (20) into the body insert upper (22). A thin smear of grease between the two metal components can help hold them together.
3. Lightly lubricate the body insert O-ring (21) and the thread of the body (4).
4. Insert the assembly into the body (4) and torque according to table below.

		Nominal torque by product size, ft·lb (N·m)		
Item	Component Name	08, 12	16	24
Tool	Socket	13 mm	24 mm	24 mm
22	Body insert upper	15 (20)	30 (40)	30 (40)

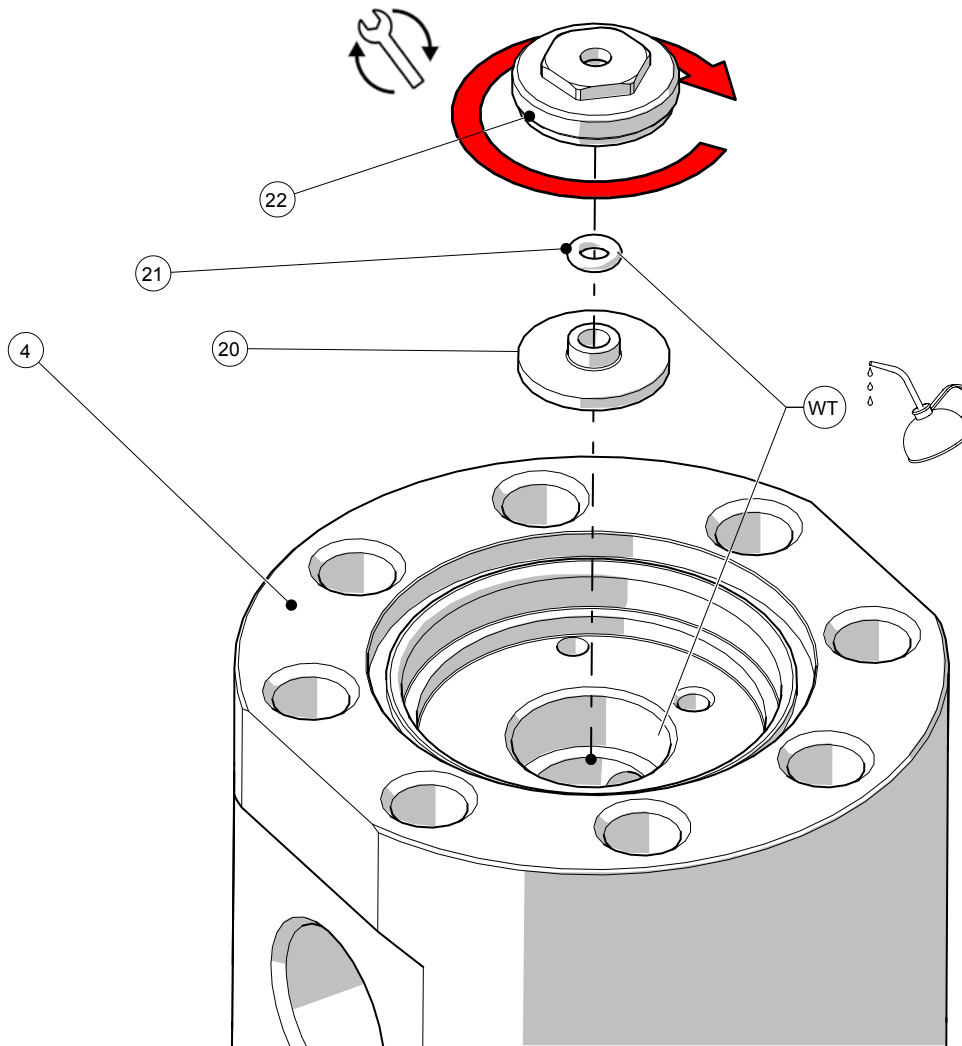

Figure 13

Step 2: Assemble Poppet

See Figure 14.

Pressure reducing poppets are provided pre-assembled by the factory. This step can be skipped if fitting a pre-assembled poppet.

1. Slide the poppet spring (12) over the poppet (5).
2. Compress the poppet spring (12) and fit the E-clip (9) onto the poppet (5).
3. Fit the poppet O-ring (8) and poppet back up ring (7) onto the poppet (5). Ensure that they are ordered correctly.

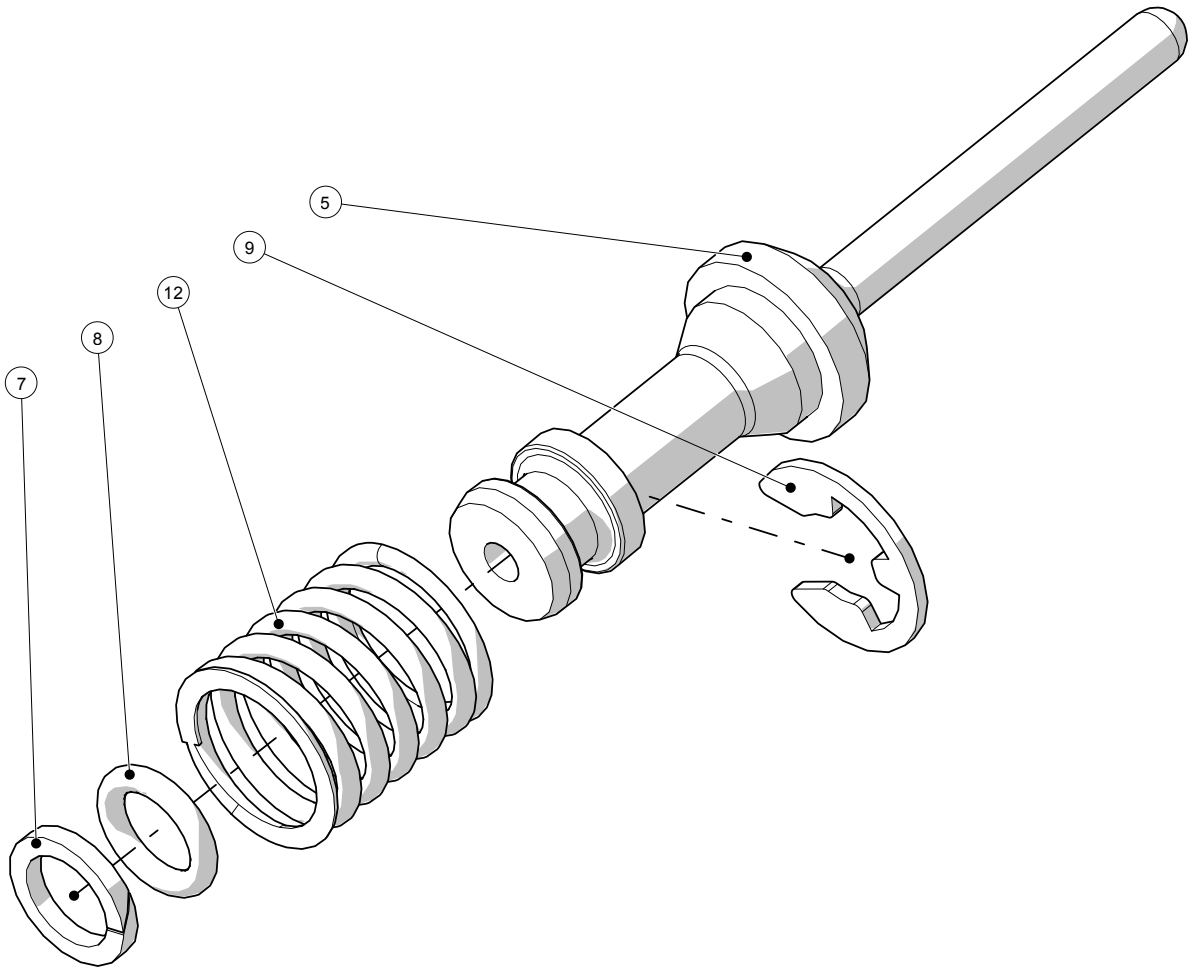

Figure 14

Step 3: Assemble Body Plug, Poppet Assembly, and Seat

See Figure 15.

1. Fit the body plug back up ring (10) and body plug O-ring (11) onto the body plug (2). Ensure that they are ordered correctly, as shown in Figure 15.
2. Lightly lubricate the body plug O-ring (11) and the body plug thread (2).
3. Lightly lubricate the poppet O-ring (8) and the surrounding area of the poppet (5).
4. Insert the poppet assembly fully into the body plug (2).
5. For both types of seat fit the seat O-ring (17) onto the raised boss on the back of the seat housing (14).
6. For low pressure seats fit the LP seat insert O-ring (16) and LP seat insert (15) into the seat housing (14).
7. Fit the seat assembly into the body ensuring that the seat O-ring (17) is facing towards the body (4).
8. Insert the body plug and poppet assembly through the seat and body insert.
9. Torque the body plug (2) according to table below.

		Nominal torque by product size, ft·lb (N·m)		
Item	Component Name	08, 12	16	24
Tool	Socket	24 mm	30 mm	30 mm
2	Body plug	30 (40)	37 (50)	52 (70)

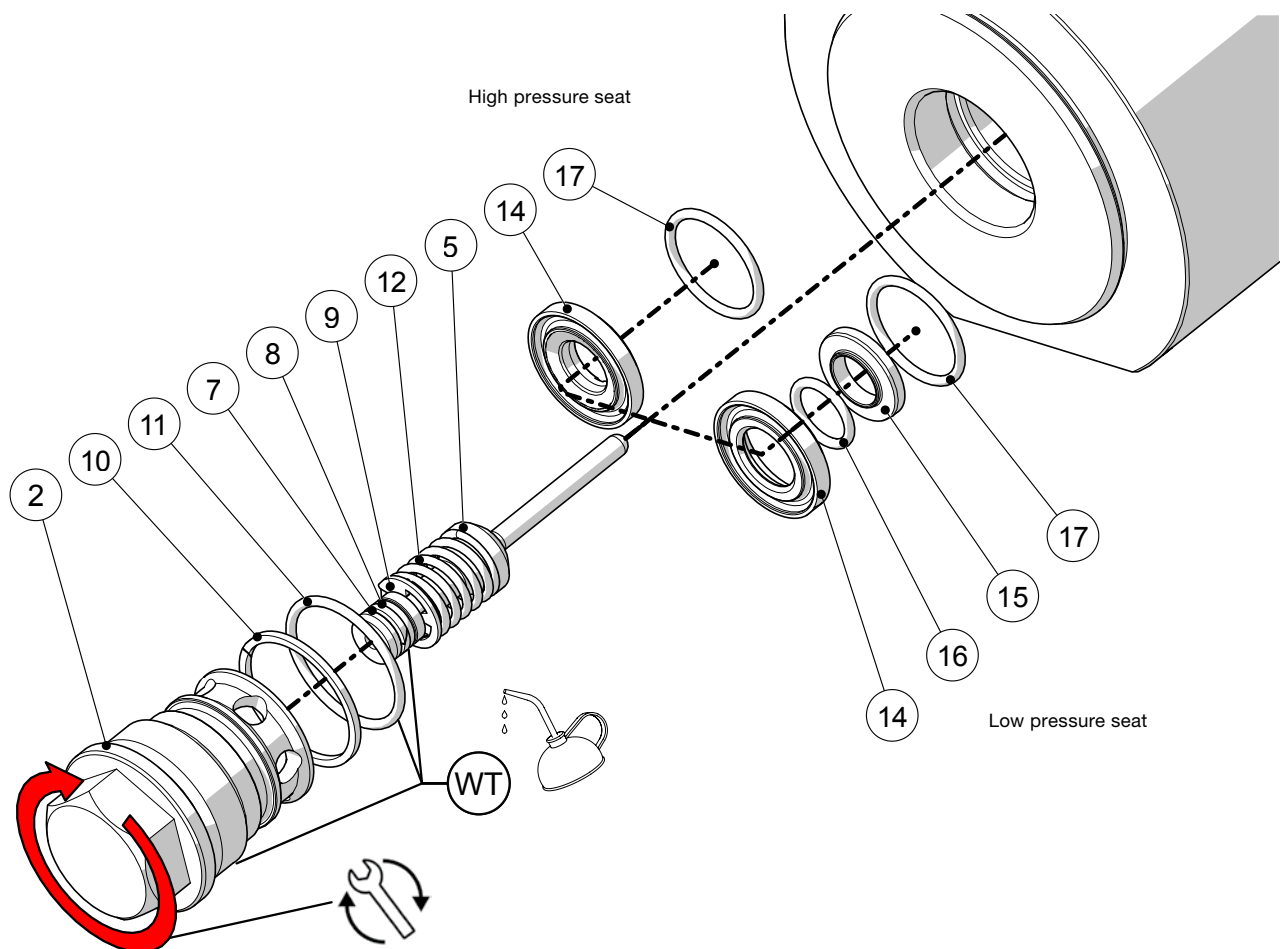

Figure 15

Step 4a: Assemble Diaphragm

See Figure 16.

Image is representative. Depending on the regulator type, the size of the diaphragm and plates may vary.

1. Fit the lower diaphragm plate (26), diaphragm (27) then upper diaphragm plate (28) onto the diaphragm screw (25). Ensure that the diaphragm (27) fully seats into the upper diaphragm plate groove (28).
2. Lightly lubricate the threads of the diaphragm screw (25).
3. Screw on the diaphragm nut (29) and torque according to the table below.
4. Insert the diaphragm assembly into the body, ensuring that the outside of the diaphragm (27) seats fully into the body (4).

		Nominal torque by product size, ft·lb (N·m)		
Item	Component Name	08, 12	16	24
Tool	Socket	24 mm	24 mm	24 mm
29	Diaphragm nut	30 (40)	30 (40)	30 (40)

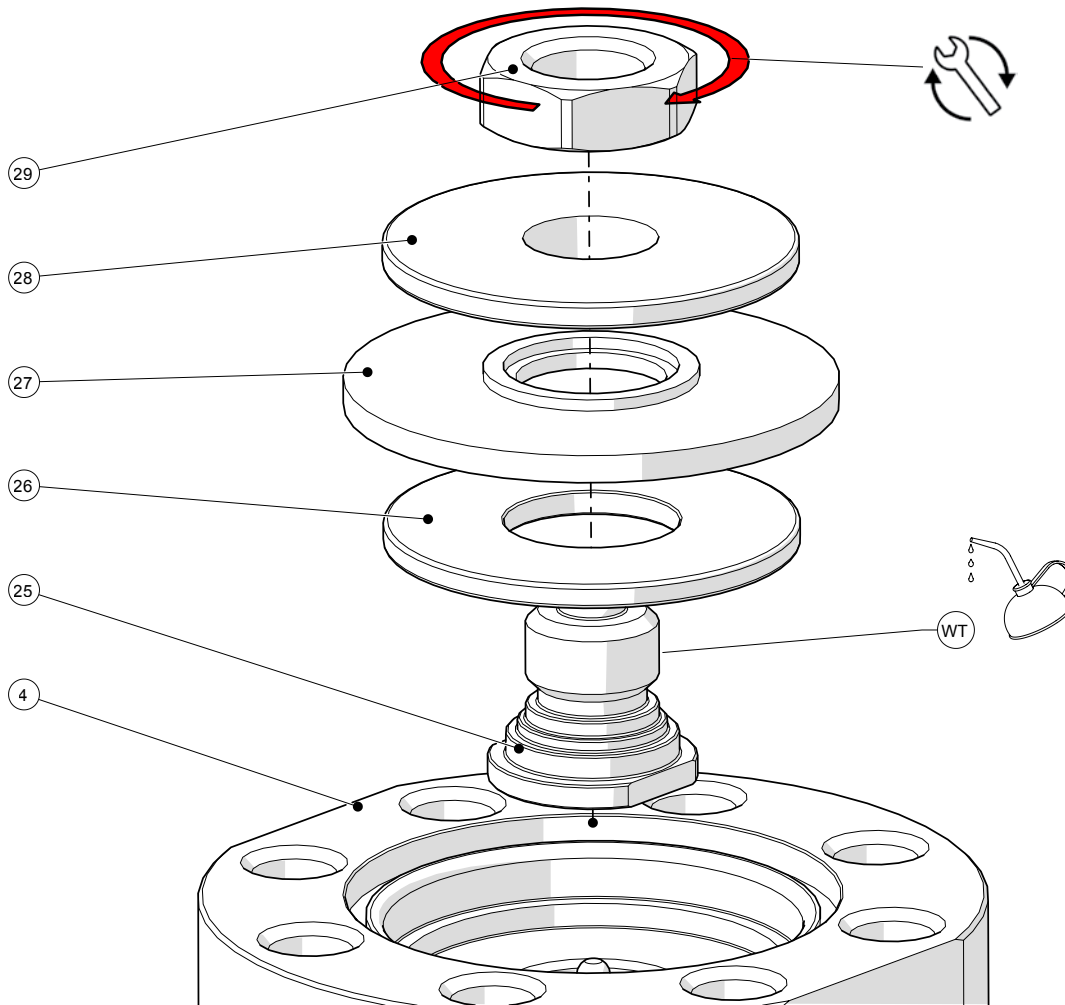

Figure 16

Step 4b: Assemble Piston

See Figure 17.

Image is representative. Depending on the pressure control range of the regulator, the size of the O-ring and back up ring may vary.

1. Lightly lubricate the primary sealing steps of the piston (30).
2. Fit the piston O-ring (33) and piston back-up ring (34) onto the piston (30). Ensure that they are ordered correctly, as shown in Figure 17.
3. Insert the piston (30) into the piston plate (31).
4. Fit the body O-ring (32) into the body (4) then fit the piston plate (31) onto the body (4) aligning the flats on both components.

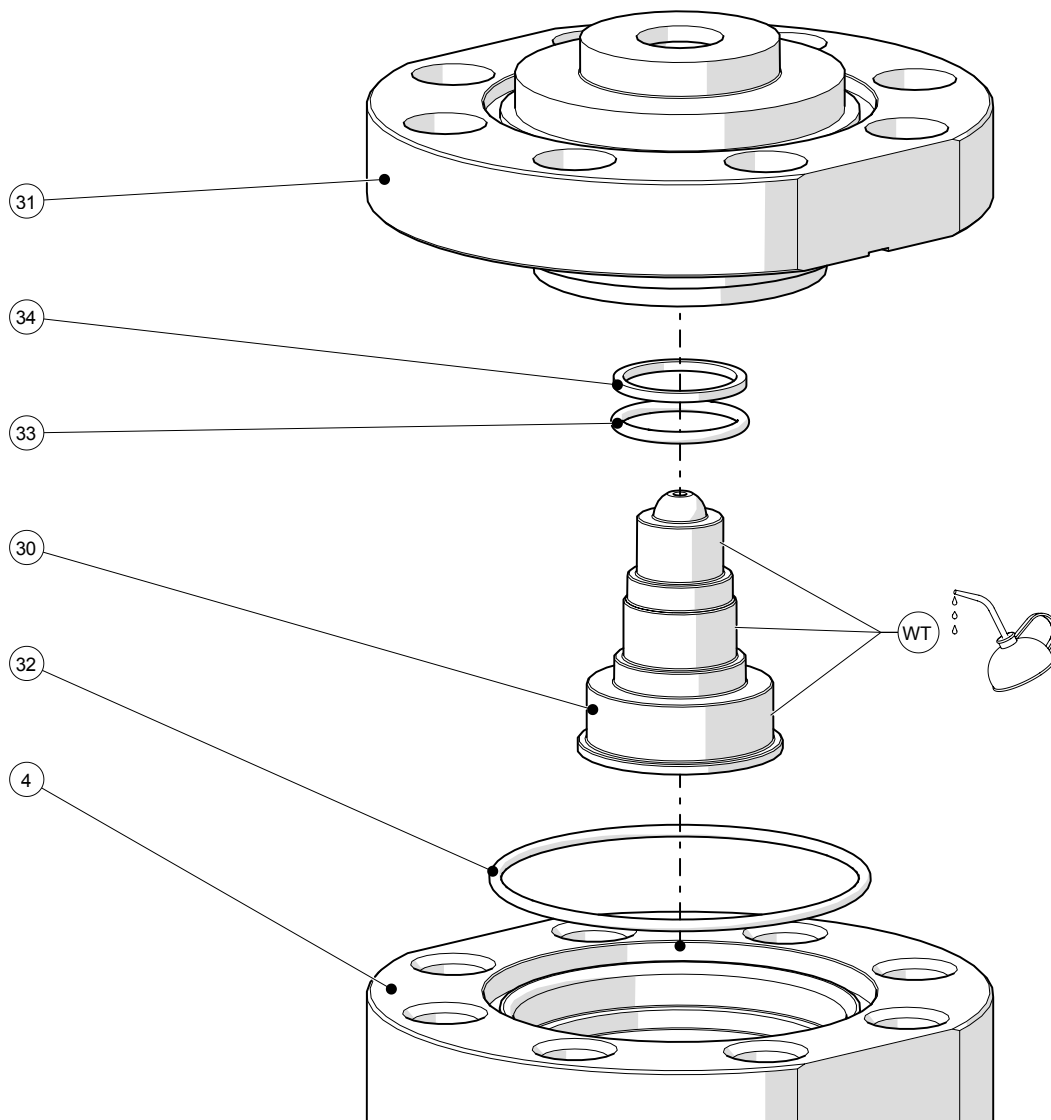

Figure 17

Step 5 (optional): Assemble Self-Vent Seat

See Figure 18.

1. Fit the self-vent seat O-ring (24) onto the self-vent seat (23).
2. Insert the self-vent seat (23) into the self-vent diaphragm screw (25) or self-vent piston (30). Ensure that the seat (23) is orientated correctly.
3. Fit the vent plate shaft O-ring (36) onto the self-vent diaphragm screw (25) or self-vent piston (30).

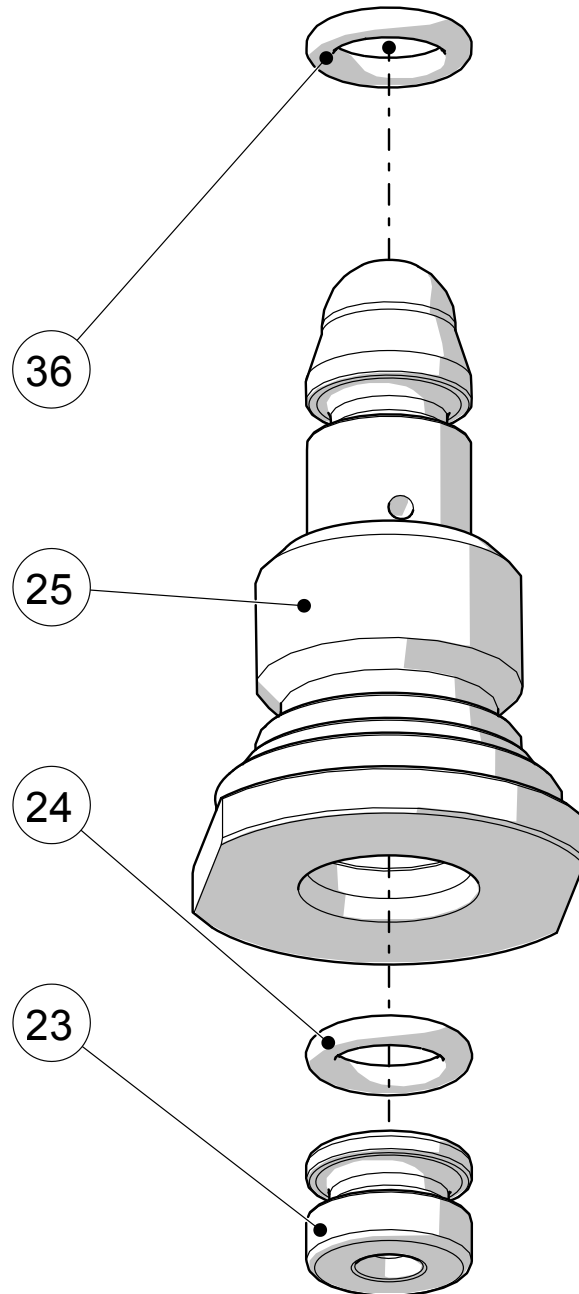

Figure 18

Step 6 (optional): Assemble Vent Plate

See Figure 19.

1. Lightly lubricate the vent plate shaft O-ring (36).
2. For piston sensing mechanisms, fit the vent plate body O-ring (37) into the piston plate (31).
3. Fit the vent plate (35) over the self-vent sensing mechanism, aligning the flats.

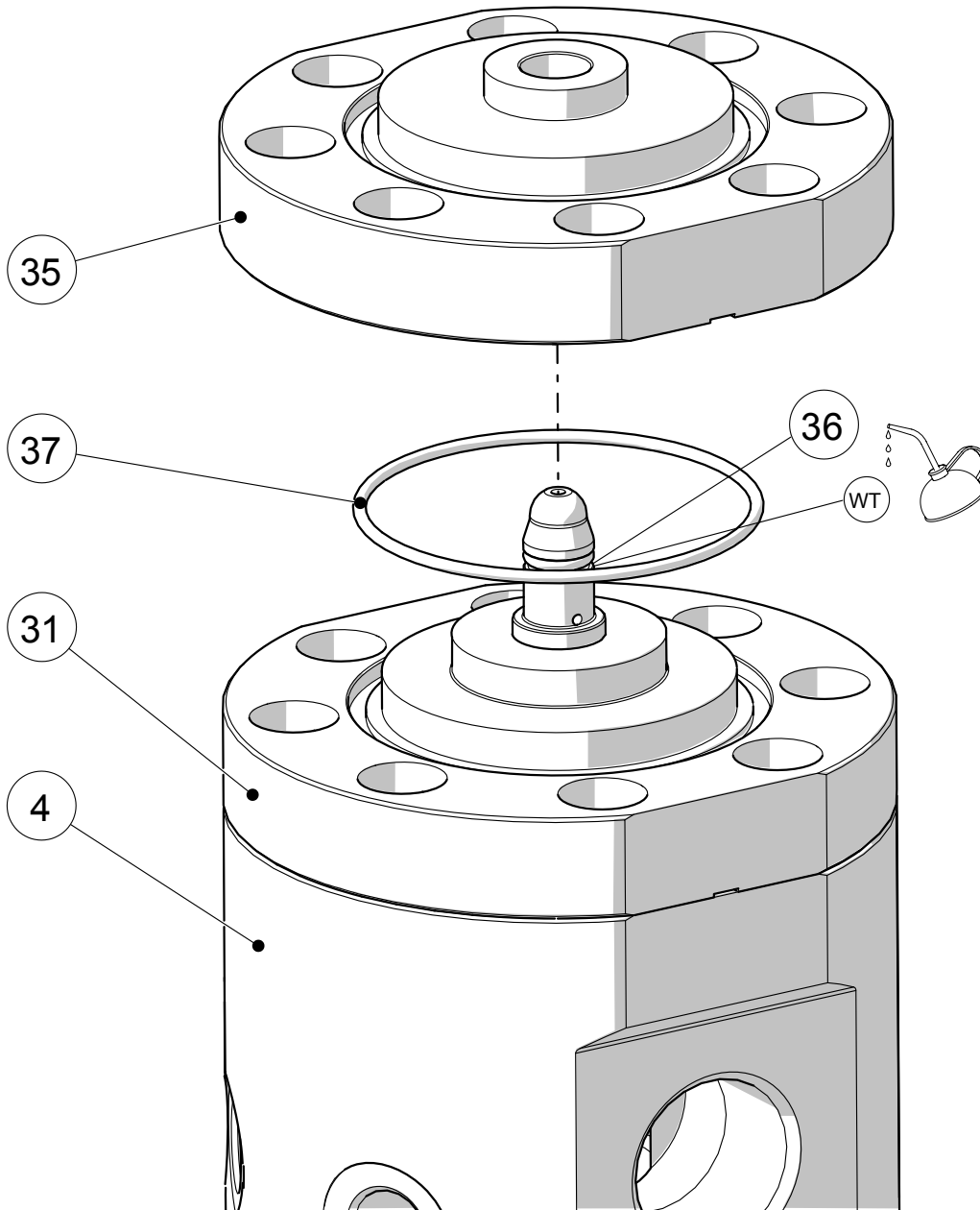

Figure 19

Step 7 (optional): Assemble Ratio Dish

See Figure 20.

Image is representative. Depending on the regulator type, the number of plates may vary.

1. Fit the ratio dish (38) on top of the assembly.
2. Lightly lubricate the first three threads of each screw (46).
3. Fit all screws (46) into the body (4) and torque, using a crisscross sequence, according to the table below.
4. Assemble and fit the diaphragm assembly according to Step 4a on page 26.

		Nominal torque by product size, ft·lb (N·m)		
Item	Component Name	08, 12	16	24
Tool	Hex drive	10 mm	14 mm	14 mm
46	Screw – cap	37 (50)	89 (120)	89 (120)

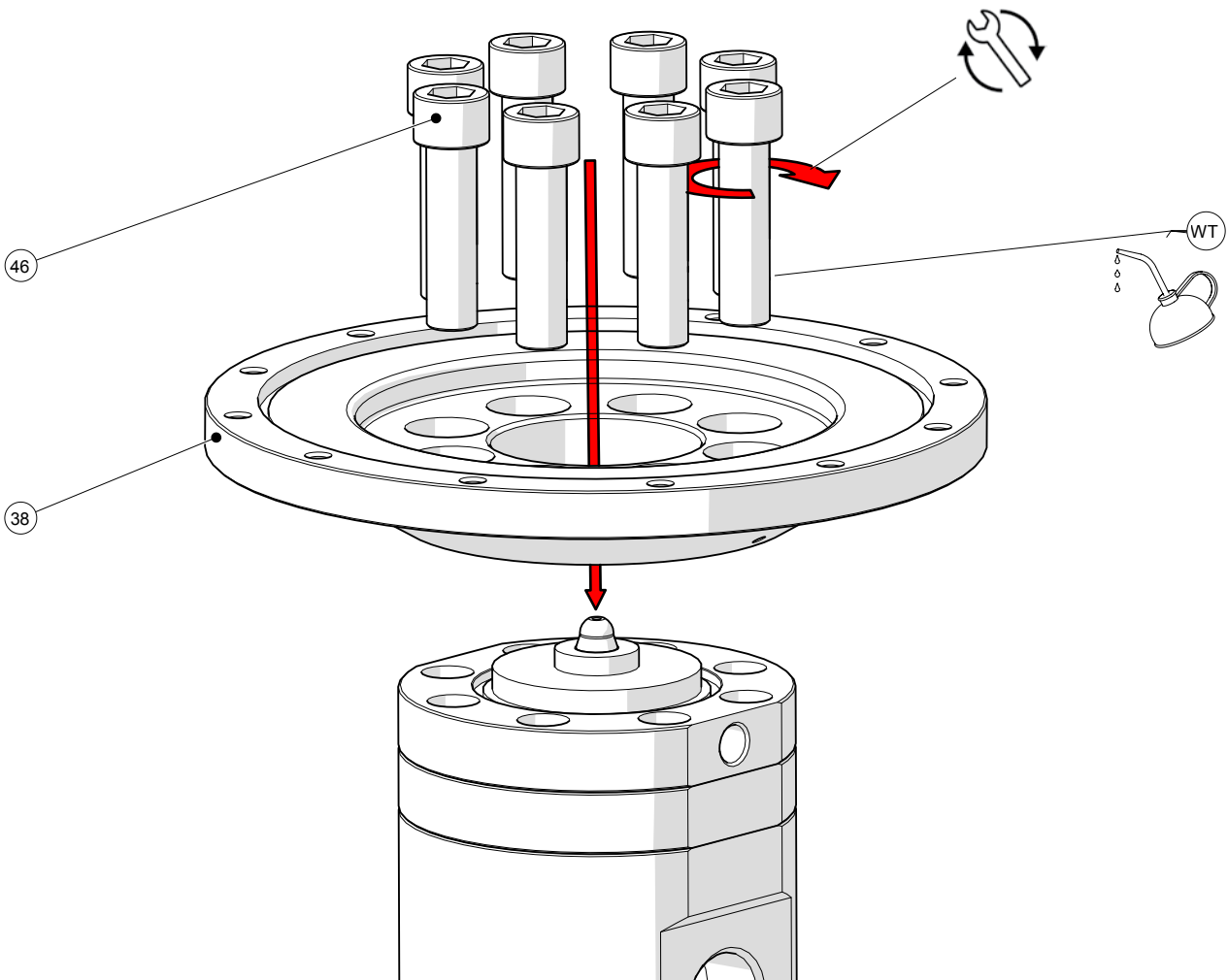

Figure 20

Step 8 (optional): Assemble Spring Housing

See Figure 21.

1. Lightly lubricate the thread of the stem (50).
2. Fully screw the upper spring button (51) onto the stem (50). Note that these components are a left-hand thread.
3. Lightly lubricate the end shaft of the stem (50) and fit the thrust washer (54) onto it. Lightly lubricate the thrust washer (54).
4. Fit the range spring (49) onto the stem. Insert this assembly into the spring housing (45).
5. Lightly lubricate the button screw (53). Orientate the upper spring button (51) so that the threaded hole faces the slot in the spring housing. Screw in the button screw (53) and torque according to table below.
6. Fit the spring damper (44) onto the lower spring button (48) then insert the lower spring button (48) into the range spring (49).

		Nominal torque by product size, ft·lb (N·m)		
Item	Component Name	08, 12	16	24
Tool	Hex drive	3 mm	3 mm	3 mm
53	Button screw	1.5 (2)	1.5 (2)	1.5 (2)

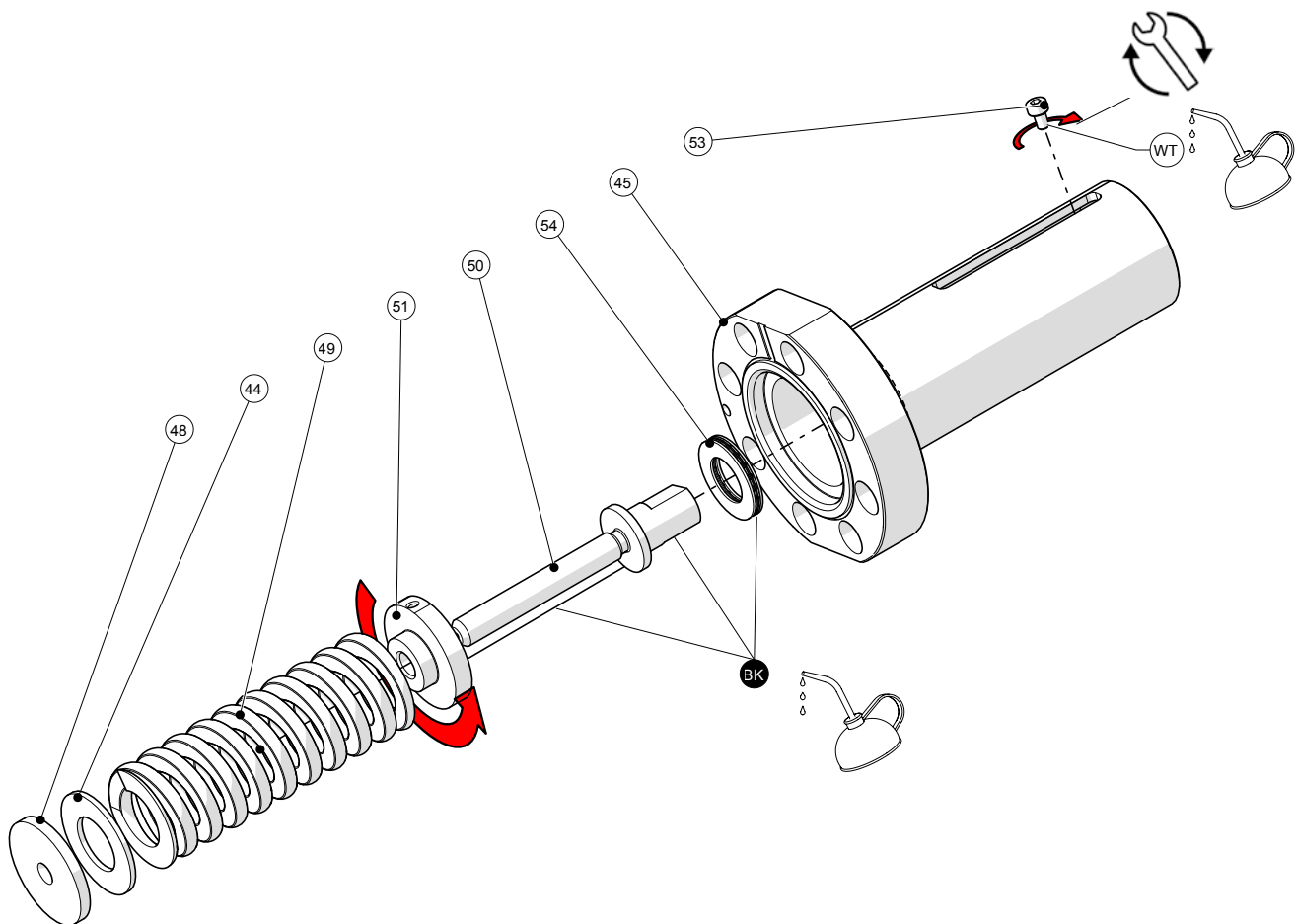

Figure 21

Step 9: Assemble Spring Housing/Dome onto Body

See Figure 22.

Image is representative. The process is the same for all spring housings and domes. The quantity of screws will vary by product series and size.

1. Fit the spring housing assembly (45) or dome (47) onto the body assembly, aligning any flat faces. For spring housings ensure that the lower spring button (48) sits on top of the spherical feature on the top of the sensing mechanism.
2. Lightly lubricate the first three threads of each screw (46 or 64).
3. Fit all screws into the body and torque, using a crisscross sequence, according to the table below.

		Nominal torque by product size, ft·lb (N·m)		
Item	Component Name	08, 12	16	24
Standard Regulators				
Tool	Hex drive	10 mm	14 mm	14 mm
46	Screws – cap	37 (50)	89 (120)	89 (120)
High Sensitivity or Ratio Regulators				
Tool	Hex drive	5 mm	5 mm	5 mm
64	Screws – high sensitivity cap	3.7 (5)	3.7 (5)	3.7 (5)

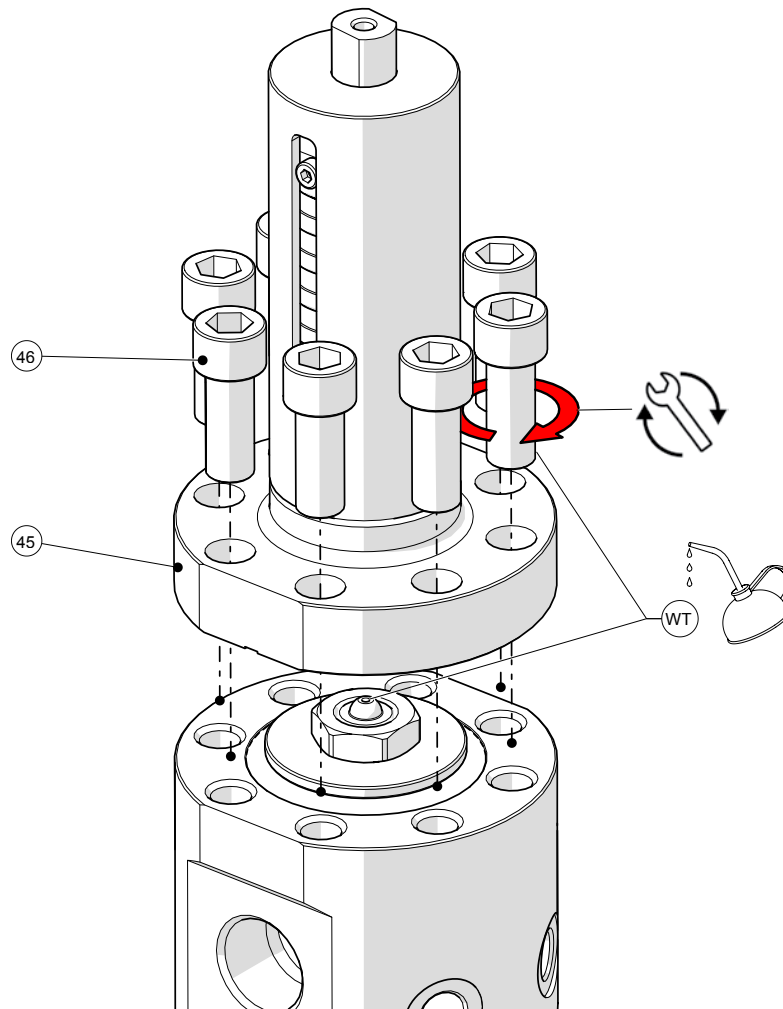

Figure 22

Step 10a (optional): Assemble Standard Handle

See Figure 23.

1. Insert the slot cover (52) into the slot in the spring housing (45). Ensure that the Swagelok logo is towards the regulator body.
2. Fit the handle (55) onto the stem (50).
3. Fit the two disk springs (56) over the stem (50). Ensure they are oriented properly with the largest diameters facing each other.
4. Lightly lubricate the thread of the stem screw (58). Fit this through the washer (57) and into the end of the stem (50). Torque according to the table below.
5. Press the handle cover (59) into the handle (55).

		Nominal torque by product size, ft·lb (N·m)		
Item	Component Name	08, 12	16	24
Tool	Hex	5 mm	5 mm	5 mm
58	Stem screw	3.7 (5)	3.7 (5)	3.7 (5)

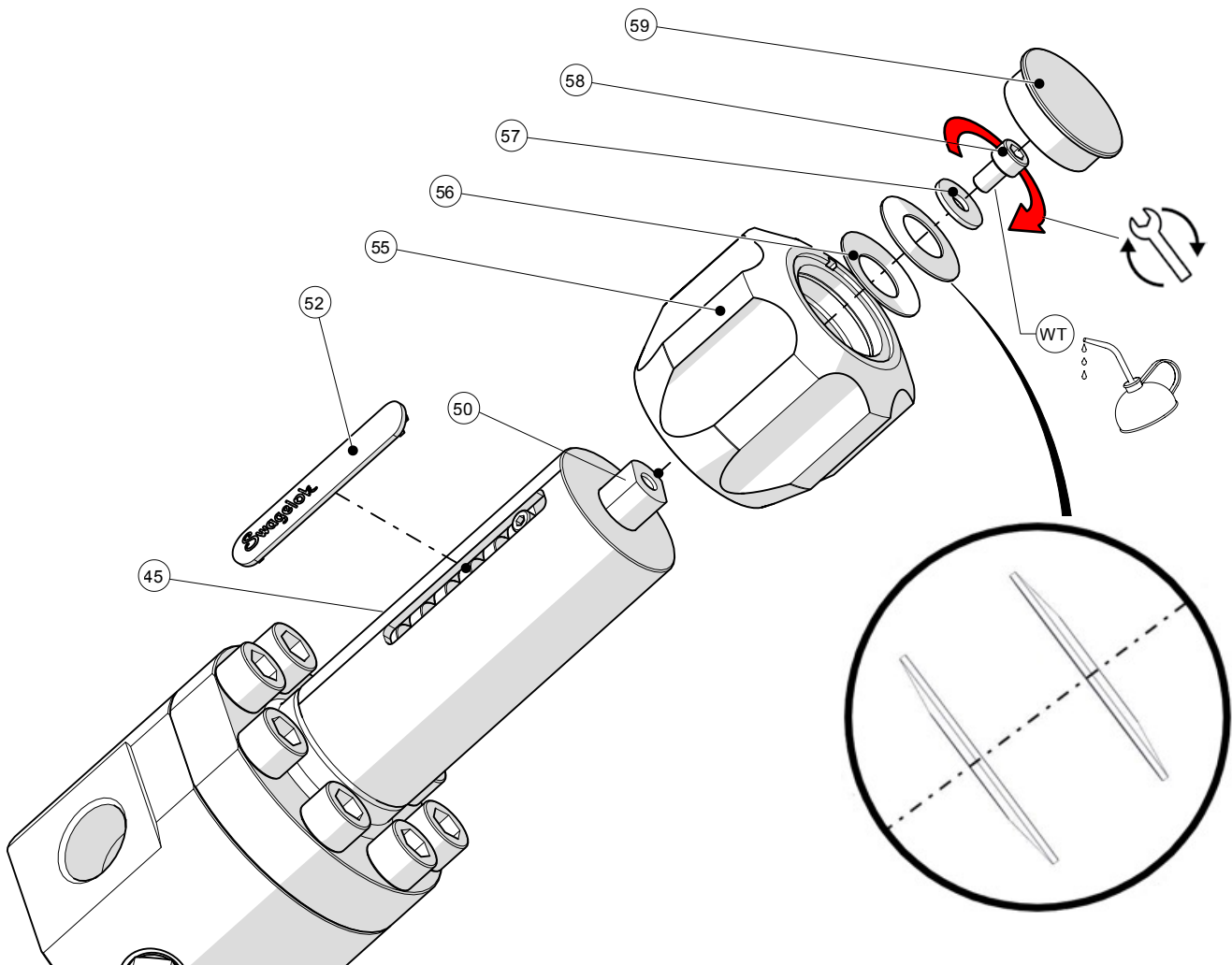

Figure 23

Step 10b (optional): Assemble Antitamper Handle

See Figure 24.

1. Insert the slot cover (52) into the slot in the spring housing (45). Ensure that the Swagelok logo is towards the regulator body.
2. Lightly lubricate the spring housing (45) around the stem (50) then fit the two disk springs (56) over the stem (50). Ensure they are oriented properly with the largest diameters are facing each other.
3. Fit the antitamper inner (60) onto the stem (50).
4. Fit the circlip (63) onto the antitamper cap (62).
5. Insert the antitamper cap (62) into the antitamper outer (61). It will click into place.
6. Fit the handle assembly onto the antitamper inner (60).
7. Lightly lubricate the thread of the stem screw (58). Fit this through the washer (57) and into the end of the stem (50). Torque according to the table below. Affix knob cover (59) to the top of the handle assembly
8. For factory set regulators, once the regulator is set as desired pull the antitamper handle (61) up to disengage it from the stem (50). Insert the clevis pin (65) through the hole in the antitamper handle (61) and wire this off to prevent removal.

		Nominal torque by product size, ft·lb (N·m)		
Item	Component Name	08, 12	16	24
Tool	Hex	5 mm	5 mm	5 mm
58	Stem screw	3.7 (5)	3.7 (5)	3.7 (5)

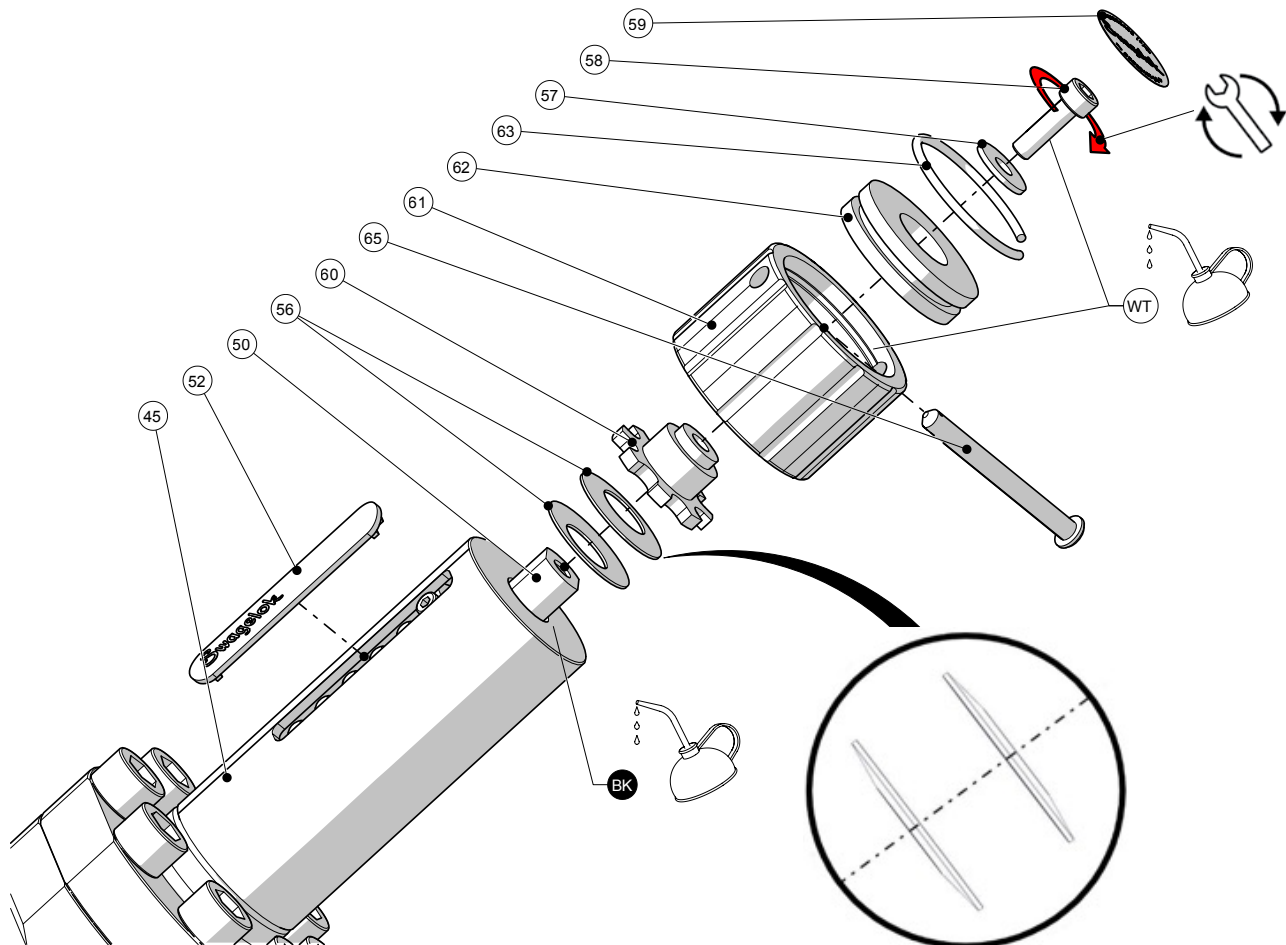

Figure 24

Step 11: Assemble Pilot Regulator

See Figure 25.

1. Insert check valve spring (74), check valve guide (75) and check valve seat (76) into the outlet auxiliary port of the body (4).
2. Install all tube fittings (70 and 77) and fitting seals (71) into the auxiliary ports according to the manufacturer's instructions.



Ensure the check valve fitting (77) is inserted into the outlet auxiliary port in the body (4). This fitting has a restricted orifice which is critical for the regulator function.

3. Connect all tubes (72) following the tube fitting manufacturer's instructions. Ensure that the tee fitting of the pilot regulator (73) connects to the outlet auxiliary port of the body (4).

Item	Component Name	Nominal torque by product size, ft·lb (N·m)		
		08, 12	16	24
Tool	Crows foot	3/4 in. (19 mm)	3/4 in. (19 mm)	3/4 in. (19 mm)
70	BSP fittings	26 (35)	26 (35)	26 (35)
77	Check valve fitting	26 (35)	26 (35)	26 (35)

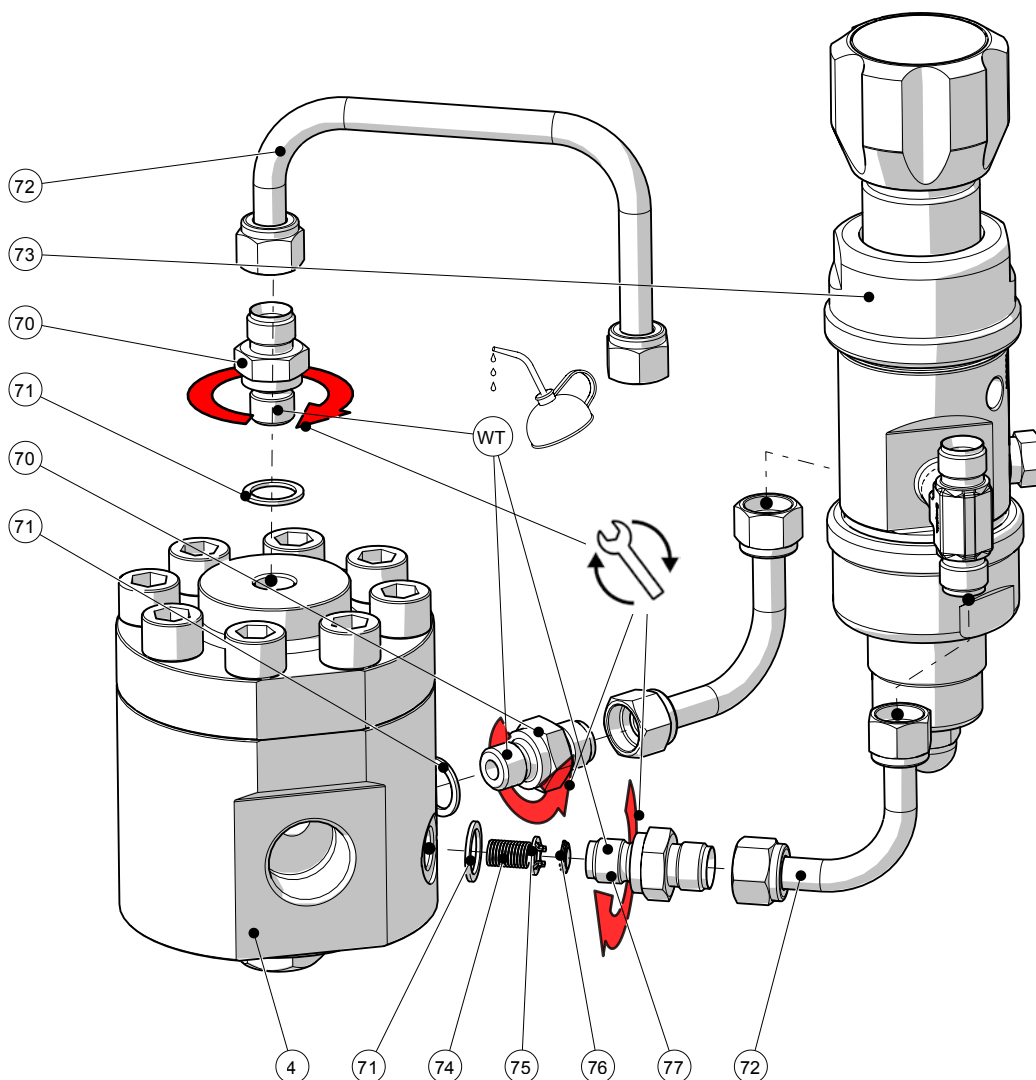

Figure 25

Testing

Swagelok recommends that the regulator be tested for seat and shell leakage to atmosphere. A well performing regulator will not show any indication of leaking. If any evidence of a leak is identified this must be addressed. Any damaged components must be replaced.

Seat Leak Test

1. Ensure there is sufficient supply pressure to the regulator to be able to perform the tests.
2. Ensure the handle is screwed fully counterclockwise or that there is zero pressure on the dome.
3. Maintain an inlet pressure of approximately 14.5 psig (1 bar) on the regulator and close the downstream shutoff valve.
4. Monitor the outlet pressure. An increase in pressure over time indicates a seat leak.
5. Repeat the procedure with the highest inlet pressure applicable for the regulator and system.

Shell Leak Test

1. Maintain an inlet pressure of approximately 29 psig (2 bar) on the regulator and close the downstream shutoff valve.
2. Increase the outlet pressure to approximately 14.5 psig (1 bar).
3. Using liquid leak detector, check for bubbles at the spring housing/dome weep hole, vent plate weep hole and body plug to body interface according to Figure 26.
4. Repeat the procedure with the highest inlet and outlet pressure applicable for the regulator and system.

Shell Leak Test Snoop® Locations

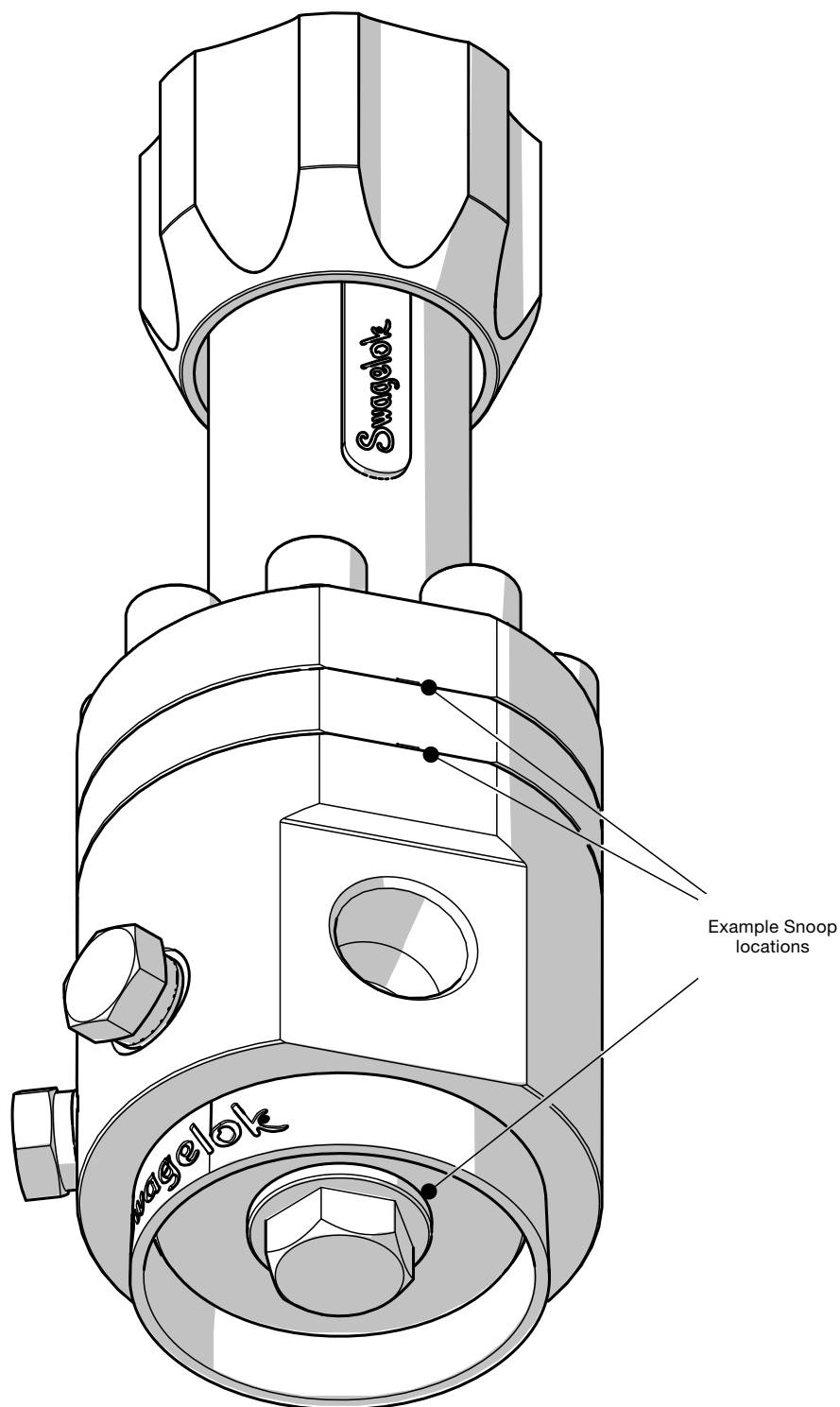

Figure 26

Regulator Tuning

Pressure regulators are a mechanical control and feedback system. Compatible with most systems, these regulators have features which allow for tuning that can improve performance and life span.

Orifice kits can be ordered that contain a 0.5 mm, 1.0 mm and 1.5 mm restrictions. See *Process Pressure Regulators* catalog, [MS-02-492](#), for details.

Feedback Rate

All pressure-reducing process regulators have a threaded internal feedback hole so that a restricted orifice can be installed if required.

- Unrestricted flow will allow the regulator to track changes in outlet pressure quickly, making them very responsive. However, if the outlet pressure fluctuates rapidly, the internal components will wear down quickly, effectively shortening the cycle life.
- Smaller restrictions will slow regulator responses down, which can help mask outlet fluctuations. This will make the regulator slower to respond, so care must be taken to limit the rate of change of flow demand.

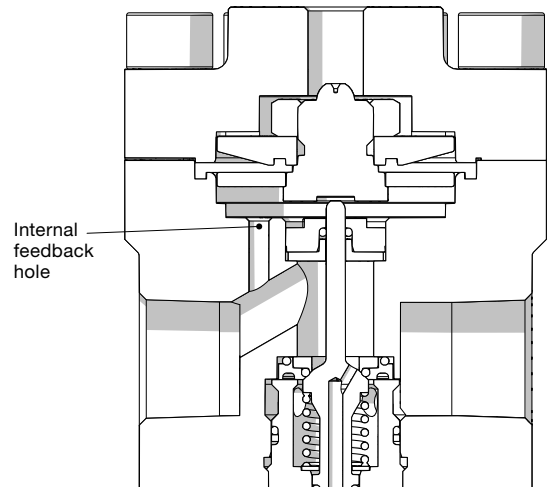

Pilot Bleed Rate

Pilot bleed rate is only applicable to dome-loaded regulators with a pilot regulator venting to the outlet. The bleed/check valve fitting has a threaded bore so that a restricted orifice can be installed if required.

- Standard bleed rates (1 mm bore) will drive the pilot regulator harder, which can be needed for low set pressures or denser fluids.
- Lower bleed rates will limit the flow of the pilot, which can be useful for high set pressures or lighter fluids.

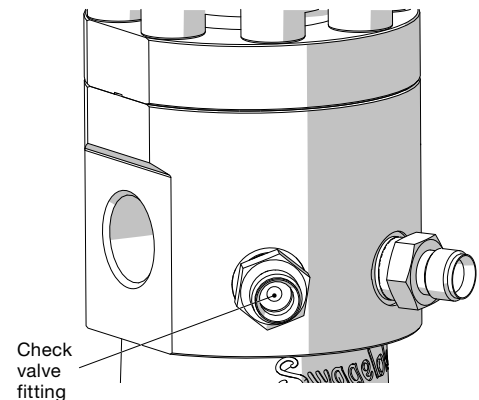

Troubleshooting

Symptom	Cause	Remedy
The outlet pressure creeps up, without adjusting the regulator.	A damaged poppet and/or seat.	Replace the poppet and/or seat.
Leakage around the body plug.	A damaged O-ring.	Replace the O-ring.
Leakage at a weep hole.	A damaged diaphragm or O-ring.	Replace the diaphragm or O-ring.
	Insufficient torque on the cap screws.	Tighten the cap screws according to table on page 32 .
Controlled pressure drops off sharply even when the flow is within regulator capabilities.	The system filter element is clogged.	Replace the system filter.
The required outlet pressure cannot be reached.	The inlet pressure to the regulator is not high enough.	Ensure that the inlet pressure to the regulator is equal to or greater than the desired set pressure.
The outlet pressure rises too much when going from a dynamic to a static situation.	There is too much flow in the dynamic situation.	A larger regulator or parallel regulator is required. Review application flow capacity and contact your local authorized sales and service center.
The outlet pressure does not drop when the knob is adjusted counterclockwise or dome pressure is reduced	The regulator is non-venting.	A shutoff valve in the outlet line must be opened to reduce the outlet pressure.
The outlet pressure has changed without adjusting the regulator.	Changes to the inlet pressure may result in changes to the outlet pressure.	Maintain a constant inlet pressure to the regulator. See <i>Points of Attention Before Operation</i> on page 7 about dependency .
	Changes to the flow may result in changes to the outlet pressure.	Maintain a constant flow through the regulator. See <i>Points of Attention Before Operation</i> on page 7 about droop .
Loud, or metallic components wearing out.	Regulator is responding too quickly to pressure fluctuations.	Trial a smaller feedback restriction. See page 38 for details.
Pilot regulator freezing (before main unit) or excessive droop.	Pilot regulator is flowing too hard.	Trial a smaller pilot restriction. See page 38 for details.

Safe Product Selection

When selecting a product, the total system design must be considered to ensure safe, trouble-free performance. Function, material compatibility, adequate ratings, proper installation, operation, and maintenance are the responsibilities of the system designer and user.

WARNING

Do not mix/interchange Swagelok products or components not governed by industrial design standards, including Swagelok tube fitting end connections, with those of other manufacturers.

Warranty Information

Swagelok products are backed by The Swagelok Limited Lifetime Warranty. For a copy, visit [swagelok.com](https://www.swagelok.com) or contact your authorized Swagelok representative.

